



# Cambridge IGCSE™

CANDIDATE  
NAME

CENTRE  
NUMBER

--	--	--	--	--

CANDIDATE  
NUMBER

--	--	--	--

**CAMBRIDGE INTERNATIONAL MATHEMATICS**

**0607/22**

Paper 2 (Extended)

**October/November 2020**

**45 minutes**

You must answer on the question paper.

You will need: Geometrical instruments

## INSTRUCTIONS

- Answer **all** questions.
- Use a black or dark blue pen. You may use an HB pencil for any diagrams or graphs.
- Write your name, centre number and candidate number in the boxes at the top of the page.
- Write your answer to each question in the space provided.
- Do **not** use an erasable pen or correction fluid.
- Do **not** write on any bar codes.
- Calculators must **not** be used in this paper.
- You may use tracing paper.
- You must show all necessary working clearly and you will be given marks for correct methods even if your answer is incorrect.
- All answers should be given in their simplest form.

## INFORMATION

- The total mark for this paper is 40.
- The number of marks for each question or part question is shown in brackets [ ].

This document has **8** pages. Blank pages are indicated.



## Formula List

For the equation  $ax^2 + bx + c = 0$   $x = \frac{-b \pm \sqrt{b^2 - 4ac}}{2a}$

Curved surface area,  $A$ , of cylinder of radius  $r$ , height  $h$ .  $A = 2\pi rh$

Curved surface area,  $A$ , of cone of radius  $r$ , sloping edge  $l$ .  $A = \pi rl$

Curved surface area,  $A$ , of sphere of radius  $r$ .  $A = 4\pi r^2$

Volume,  $V$ , of pyramid, base area  $A$ , height  $h$ .  $V = \frac{1}{3}Ah$

Volume,  $V$ , of cylinder of radius  $r$ , height  $h$ .  $V = \pi r^2 h$

Volume,  $V$ , of cone of radius  $r$ , height  $h$ .  $V = \frac{1}{3}\pi r^2 h$

Volume,  $V$ , of sphere of radius  $r$ .  $V = \frac{4}{3}\pi r^3$

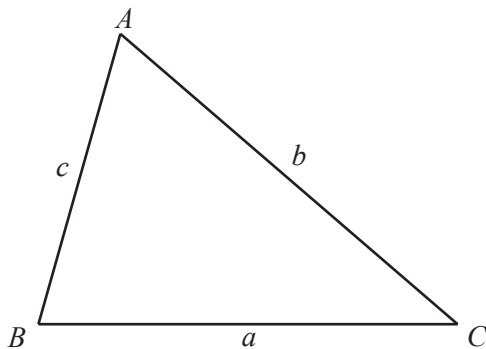

$$\frac{a}{\sin A} = \frac{b}{\sin B} = \frac{c}{\sin C}$$

$$a^2 = b^2 + c^2 - 2bc \cos A$$

$$\text{Area} = \frac{1}{2}bc \sin A$$

Answer **all** the questions.

- 1 A quadrilateral has rotational symmetry of order two, two lines of symmetry and its angles are **not** right angles.

What is the special name of this quadrilateral?

..... [1]

- 2 Work out the exact value of  $\sqrt{2\frac{7}{9}}$ .

..... [2]

- 3 These are the first four terms in a sequence.

27    19    11    3

(a) Write down the next term.

..... [1]

(b) Find an expression, in terms of  $n$ , for the  $n$ th term of the sequence.

..... [2]

- 4 Work out  $(64)^{-\frac{2}{3}}$ .

..... [2]

- 5  $v = u + at$

Find  $v$  when  $u = 5$ ,  $a = -3$  and  $t = 4$ .

$v =$  ..... [2]

6

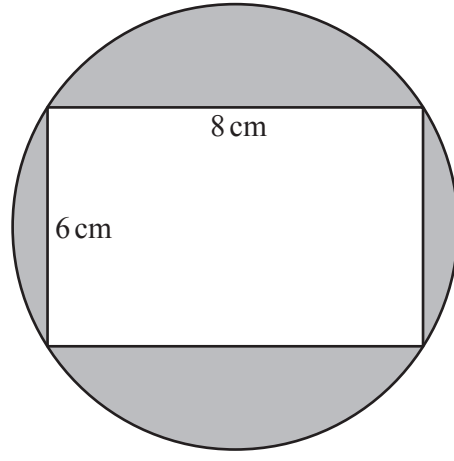

NOT TO SCALE

The four vertices of the rectangle each lie on the circle.

Find the shaded area.

Give your answer, in terms of  $\pi$ , in its simplest form.

.....  $\text{cm}^2$  [4]

7 5 numbers have a mean of 12.  
When a 6th number is included the mean is 9.

Work out the 6th number.

..... [2]

8 Written as the product of its prime factors,  $540 = 2^2 \times 3^3 \times 5$ .

(a) Write 360 as a product of its prime factors.

..... [2]

(b) Find the highest common factor (HCF) of 540 and 360.

..... [1]

(c)  $540n$  is a cube number.

Find the smallest possible value of  $n$ .

..... [1]

9 Pierre records the colour of each of 200 cars passing his home.  
The table shows the results.

Colour	Silver	Black	Red	Green	Blue	Other
Frequency	23	68	35	20	32	22

(a) Write down the relative frequency of a silver car.

..... [1]

(b) Explain why it is reasonable to use the answer to **part (a)** as the probability that the next car which passes will be silver.

..... [1]

(c) Over the whole day 1200 vehicles pass Pierre's home.

Estimate the number of these cars that are silver.

..... [1]

10 Factorise

(a)  $x^2 - x - 6$ ,

..... [2]

(b)  $3ax + 2bx - 4by - 6ay$ .

..... [2]

11 (a) In each Venn diagram, shade the given set.

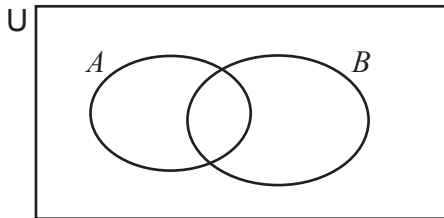

$A \cup B$

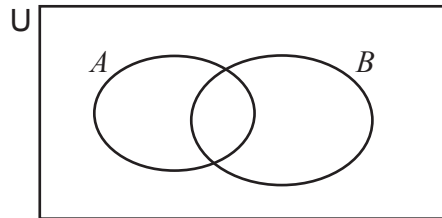

$(A \cap B)'$

[2]

(b) In this Venn diagram, the number of elements in each of the subsets is shown.

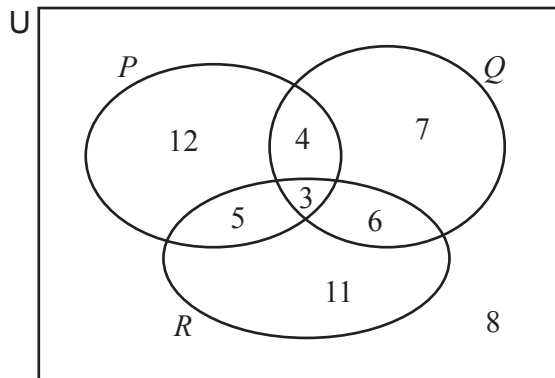

Find.

(i)  $n(P \cup (Q \cap R))$

..... [1]

(ii)  $n((P \cup Q) \cap R')$

..... [1]

12

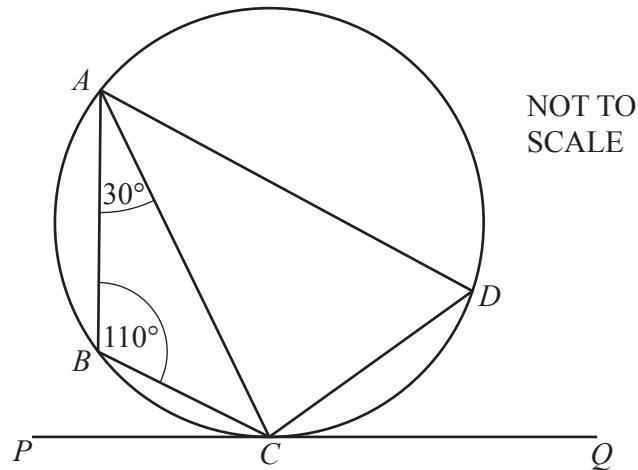

The points  $A$ ,  $B$ ,  $C$  and  $D$  lie on a circle.  
 $PCQ$  is a tangent to the circle at  $C$ .  
 Angle  $ABC = 110^\circ$  and angle  $BAC = 30^\circ$ .

Find

(a) angle  $ADC$ ,

Angle  $ADC = \dots\dots\dots$  [1]

(b) angle  $ACP$ ,

Angle  $ACP = \dots\dots\dots$  [1]

(c) angle  $PCB$ .

Angle  $PCB = \dots\dots\dots$  [1]

13 (a) Find  $\log_3\left(\frac{1}{9}\right)$ .

$\dots\dots\dots$  [1]

(b) Solve  $\log x + 2 \log 5 = \log 15$ .

$\dots\dots\dots$  [2]

Question 14 is printed on the next page.

- 14 A rectangular piece of paper has sides of length  $a$  cm and  $b$  cm.

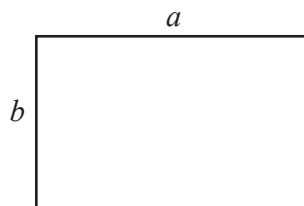

NOT TO  
SCALE

The paper is cut in half.

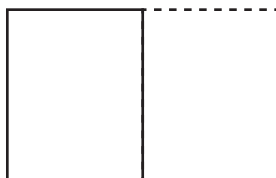

The ratio of the length of the longer side to the length of the shorter side in both pieces of paper is the same.

Find  $a$  in terms of  $b$ .

$$a = \dots\dots\dots [3]$$

Permission to reproduce items where third-party owned material protected by copyright is included has been sought and cleared where possible. Every reasonable effort has been made by the publisher (UCLES) to trace copyright holders, but if any items requiring clearance have unwittingly been included, the publisher will be pleased to make amends at the earliest possible opportunity.

To avoid the issue of disclosure of answer-related information to candidates, all copyright acknowledgements are reproduced online in the Cambridge Assessment International Education Copyright Acknowledgements Booklet. This is produced for each series of examinations and is freely available to download at [www.cambridgeinternational.org](http://www.cambridgeinternational.org) after the live examination series.

Cambridge Assessment International Education is part of the Cambridge Assessment Group. Cambridge Assessment is the brand name of the University of Cambridge Local Examinations Syndicate (UCLES), which itself is a department of the University of Cambridge.