

CANDIDATE
NAME

--

CENTRE
NUMBER

--	--	--	--	--

CANDIDATE
NUMBER

--	--	--	--



CAMBRIDGE INTERNATIONAL MATHEMATICS

0607/42

Paper 4 (Extended)

October/November 2018

2 hours 15 minutes

Candidates answer on the Question Paper.

Additional Materials: Geometrical Instruments
 Graphics Calculator

READ THESE INSTRUCTIONS FIRST

Write your Centre number, candidate number and name on all the work you hand in.

Write in dark blue or black pen.

Do not use staples, paper clips, glue or correction fluid.

You may use an HB pencil for any diagrams or graphs.

DO NOT WRITE IN ANY BARCODES.

Answer **all** the questions.

Unless instructed otherwise, give your answers exactly or correct to three significant figures as appropriate.

Answers in degrees should be given to one decimal place.

For π , use your calculator value.

You must show all the relevant working to gain full marks and you will be given marks for correct methods, including sketches, even if your answer is incorrect.

The number of marks is given in brackets [] at the end of each question or part question.

The total number of marks for this paper is 120.

This document consists of **18** printed pages and **2** blank pages.

Formula List

For the equation $ax^2 + bx + c = 0$ $x = \frac{-b \pm \sqrt{b^2 - 4ac}}{2a}$

Curved surface area, A , of cylinder of radius r , height h . $A = 2\pi rh$

Curved surface area, A , of cone of radius r , sloping edge l . $A = \pi rl$

Curved surface area, A , of sphere of radius r . $A = 4\pi r^2$

Volume, V , of pyramid, base area A , height h . $V = \frac{1}{3}Ah$

Volume, V , of cylinder of radius r , height h . $V = \pi r^2 h$

Volume, V , of cone of radius r , height h . $V = \frac{1}{3}\pi r^2 h$

Volume, V , of sphere of radius r . $V = \frac{4}{3}\pi r^3$



$$\frac{a}{\sin A} = \frac{b}{\sin B} = \frac{c}{\sin C}$$

$$a^2 = b^2 + c^2 - 2bc \cos A$$

$$\text{Area} = \frac{1}{2}bc \sin A$$

Answer **all** the questions.

1 Adila has \$10 000.

- (a) She uses some of the money to buy a car.
The salesman reduces the price from \$3800 to \$3610.

Calculate the percentage reduction.

.....% [3]

- (b) Adila invests the remaining \$6390 at a rate of 3% per year compound interest.

- (i) Find the value of the investment at the end of 5 years.

\$ [3]

- (ii) Find the least number of complete years after which the value of the investment is more than \$9000.

..... [4]

2 Here are 12 numbers.

15 9 6 14 6 8 12 21 11 19 6 12

(a) For these numbers find

(i) the range,

..... [1]

(ii) the mode,

..... [1]

(iii) the median,

..... [1]

(iv) the mean,

..... [1]

(v) the inter-quartile range.

..... [2]

(b) Dee chooses a number at random from these numbers.

Find the probability that it is a prime number.

..... [1]

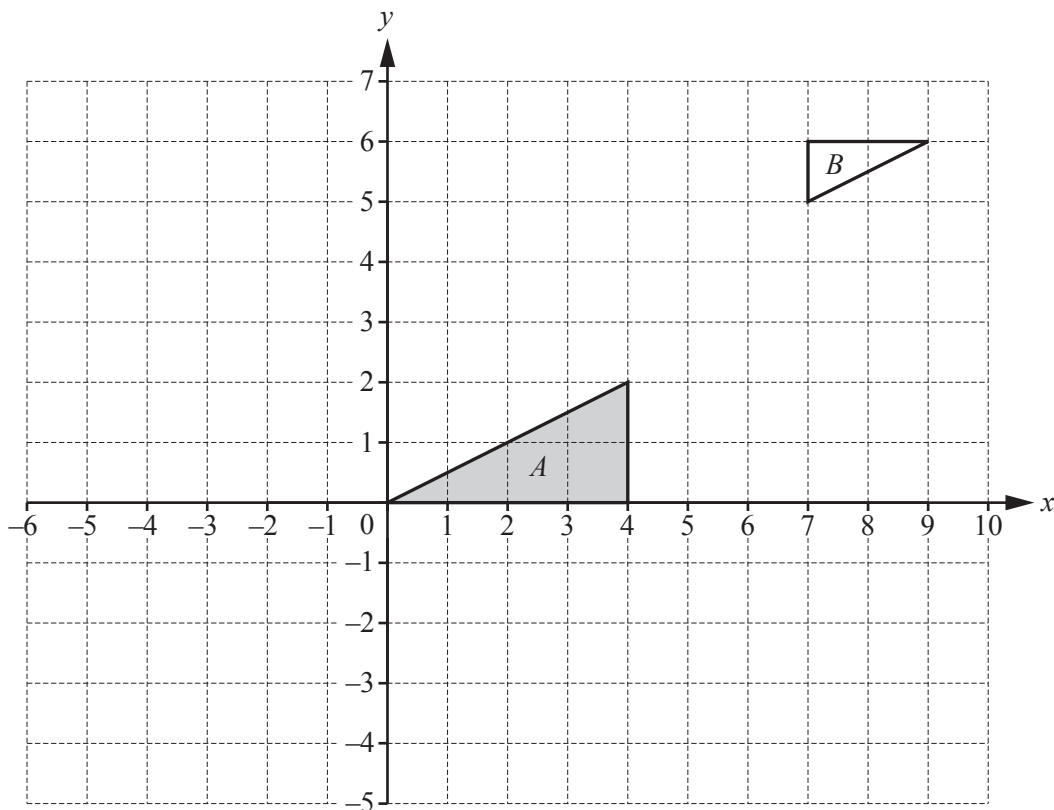

(a) Translate triangle *A* by the vector $\begin{pmatrix} -5 \\ 3 \end{pmatrix}$. [2]

(b) Describe fully the **single** transformation that maps triangle *A* onto triangle *B*.
 [3]

(c) Describe fully the **single** transformation that is equivalent to a reflection in $y = -x$ followed by a reflection in the *y*-axis.
 You may use the grid below to help you.
 [3]

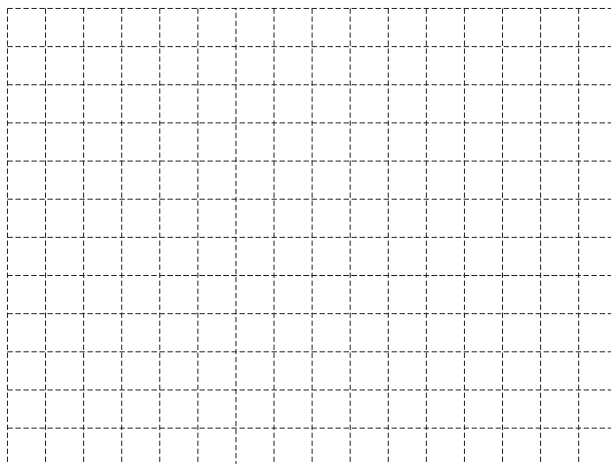

- 4 (a) y varies directly as the square of $(x + 2)$.
When $x = 3, y = 100$.

(i) Find an equation connecting x and y .

..... [2]

(ii) Find the value of y when $x = 18$.

..... [1]

(iii) Find the values of x when $y = 25$.

..... [2]

- (b) z varies inversely as \sqrt{w} .
When $w = A, z = 18$.

Find the value of z when $w = \frac{A}{9}$.

..... [2]

5

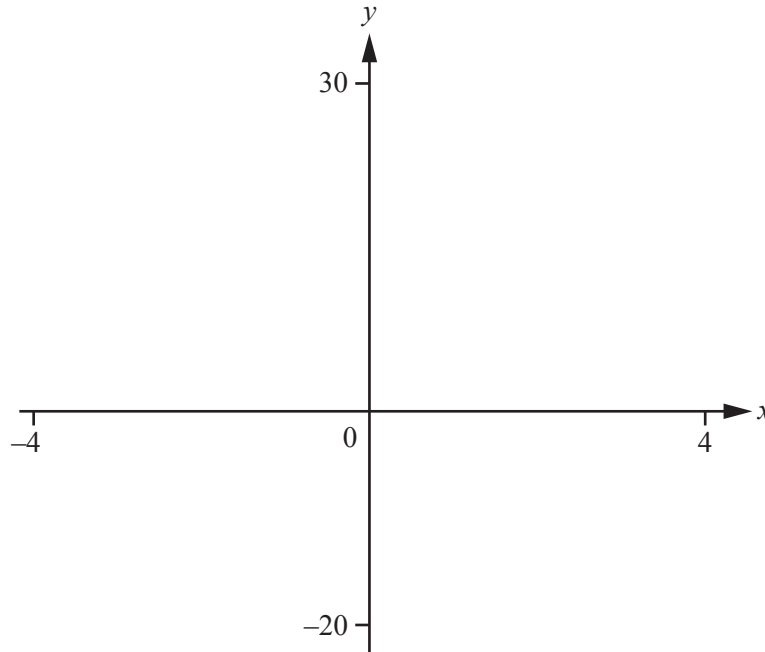

$$f(x) = x^3 - 12x + 6$$

(a) On the diagram, sketch the graph of $y = f(x)$ for $-4 \leq x \leq 4$. [2]

(b) Find the positive zeros of $f(x)$.
..... [2]

(c) Find the co-ordinates of
(i) the local maximum,
(.....,)[1]

(ii) the local minimum.
(.....,)[1]

(d) Describe fully the symmetry of the graph of $y = f(x)$.
.....
..... [3]

6

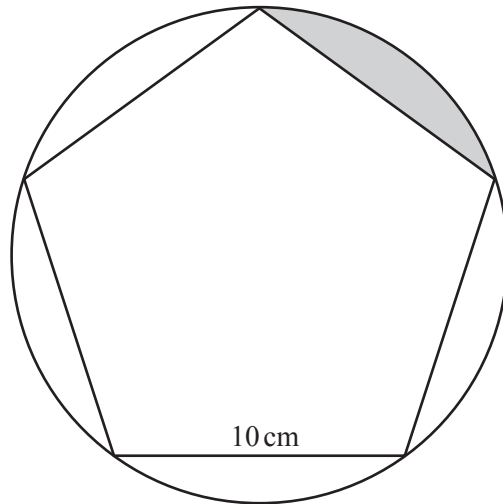

NOT TO SCALE

The diagram shows a regular pentagon, of side 10 cm, with its vertices lying on a circle.

(a) Show that the radius of the circle is 8.51 cm, correct to 3 significant figures.

[4]

(b) Calculate

(i) the perimeter of the shaded segment,

..... cm [3]

(ii) the area of the shaded segment.

.....cm² [3]

7 The length of the Jinghu high speed railway from Beijing to Shanghai is 1318 km.

- (a) A train travels at an average speed of 252 km/h.
This train leaves Beijing at 12 49.
The local time in Beijing is the same as the local time in Shanghai.

Find the time, correct to the nearest minute, that this train arrives in Shanghai.

..... [4]

- (b) On the journey this train passes over a bridge of length 6772 m at 252 km/h.
The train is 401 m long.

- (i) Change 252 kilometres per hour to metres per second.

..... m/s [2]

- (ii) Calculate the time, in seconds, for the train to completely cross the bridge.

..... s [2]

- 8 The 150 members of a sports club were asked if they played cricket (C), hockey (H) or tennis (T). Some members play none of the three sports.

The Venn diagram shows the numbers of members who play the three sports.

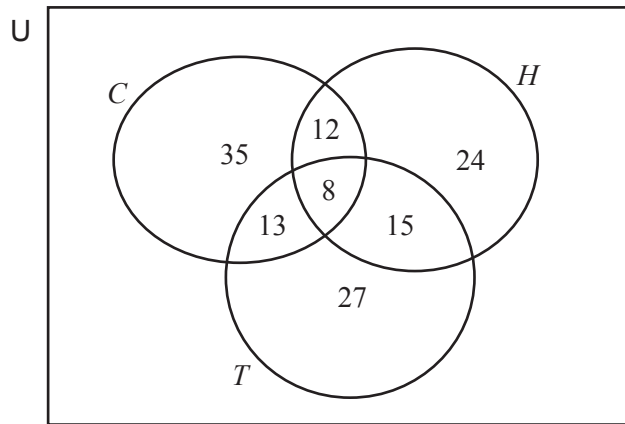

- (a) Calculate the number of members who play none of the three sports.

..... [1]

- (b) Two of the 150 members are picked at random.

Calculate the probability that

- (i) they both play hockey and tennis but not cricket,

..... [2]

- (ii) they are both members of the set $(C \cup H) \cap T'$.

..... [3]

- (c) Three of the members who play tennis are chosen at random.

Calculate the probability that none of them play cricket.

..... [3]

- 9 120 students each took two mathematics examinations, Paper 1 and Paper 2. The marks for Paper 1 are shown below.

Mark (m)	Frequency
$10 < m \leq 20$	2
$20 < m \leq 30$	4
$30 < m \leq 40$	6
$40 < m \leq 50$	12
$50 < m \leq 60$	22
$60 < m \leq 70$	34
$70 < m \leq 80$	28
$80 < m \leq 90$	12

- (a) Complete the cumulative frequency diagram to show the results. The first section has been drawn for you.

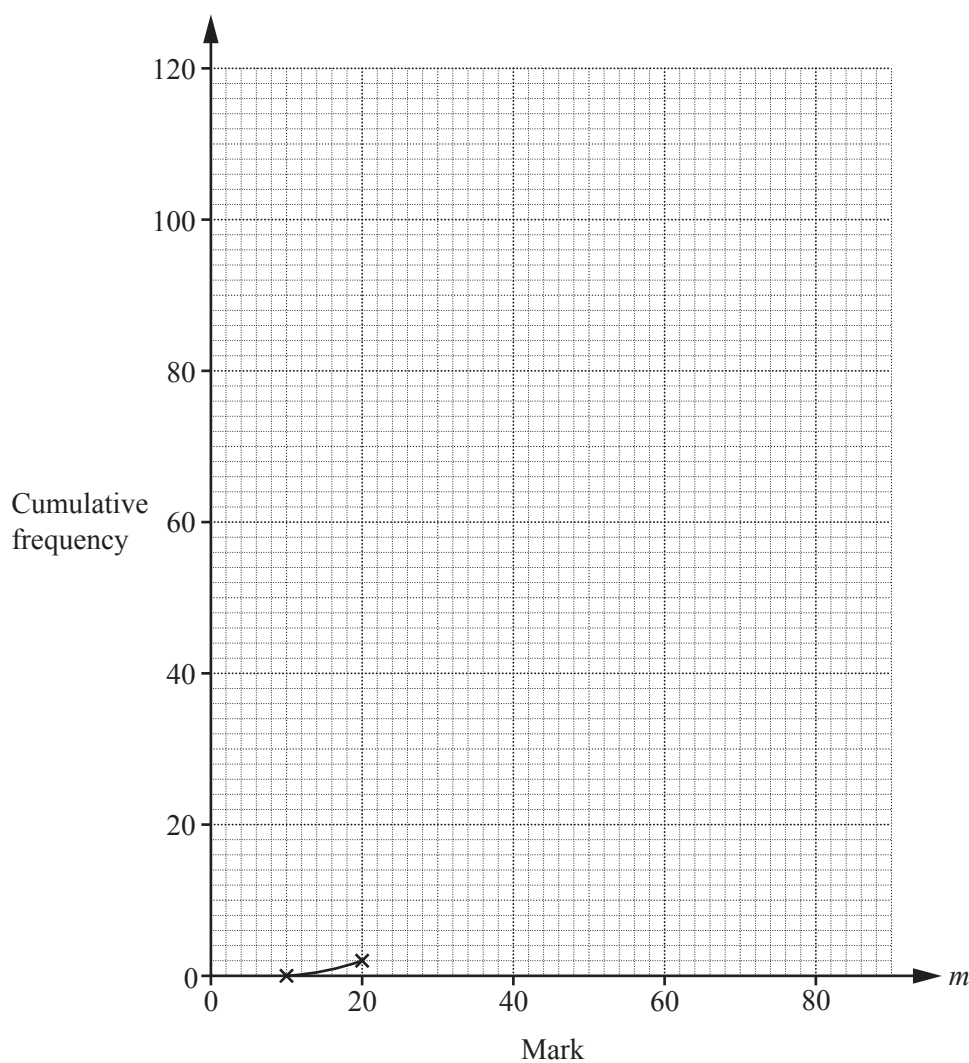

[4]

(b) Use your cumulative frequency diagram to estimate

(i) the median mark,

..... [1]

(ii) the inter-quartile range,

..... [2]

(iii) the number of students with a mark greater than 84.

..... [2]

(c) The table below shows some information about Paper 2.

Lowest mark	4
Highest mark	80
Median	44
Lower Quartile	32
Inter-quartile range	24

On the grid opposite, draw the cumulative frequency diagram for Paper 2.

[3]

10

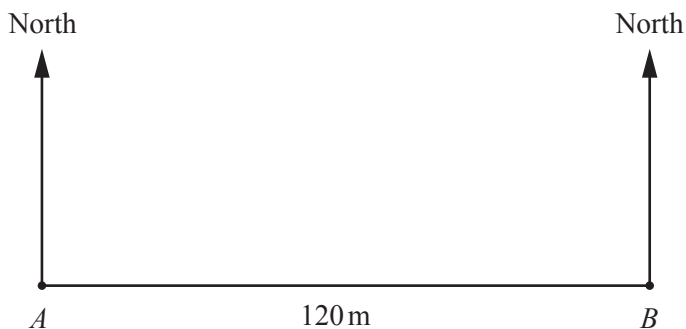

NOT TO SCALE



In the diagram, point B is due east of point A .

- (a) Point C is on a bearing of 060° from A and a bearing of 325° from B .

Calculate the distance BC .

$BC = \dots\dots\dots$ m [4]

- (b) Point D is South of AB .
 D is 80 m from A and 90 m from B .

Calculate the bearing of D from B .

$\dots\dots\dots$ [4]

11

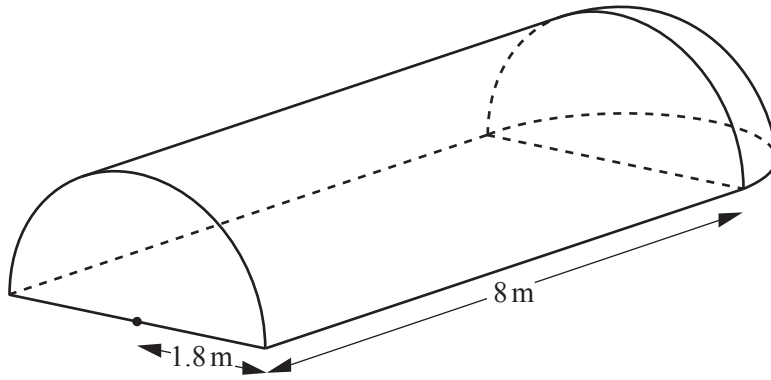

NOT TO SCALE

The diagram shows a polythene structure in which a farmer grows vegetables. The structure consists of a prism with a quarter of a sphere at **one** end. The cross-section of the prism is a semicircle.

The semicircle has a radius of 1.8 m and the length of the prism is 8 m.

(a) Calculate the volume of the structure.

.....m³ [3]

(b) The curved surface of the prism and the two ends of the structure are made of polythene.

Calculate the area of the polythene.

.....m² [4]

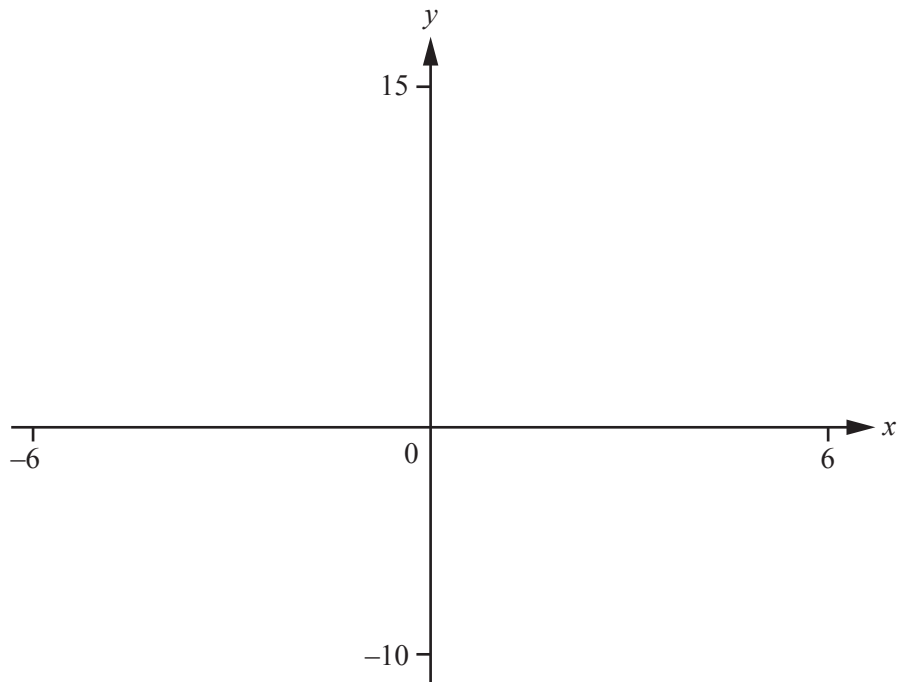

$$f(x) = \frac{(2x - 3)}{(x + 2)}$$

(a) On the diagram, sketch the graph of $y = f(x)$ for values of x between -6 and 6 . [3]

(b) Write down the equations of the asymptotes of $y = f(x)$.

.....
..... [2]

(c) $g(x) = 5 - 2x$

(i) Solve $f(x) = g(x)$.

$x = \dots\dots\dots$ or $x = \dots\dots\dots$ [2]

(ii) Find $g(f(x))$.
Give your answer as a single fraction in its simplest form.

..... [3]

13

NOT TO SCALE

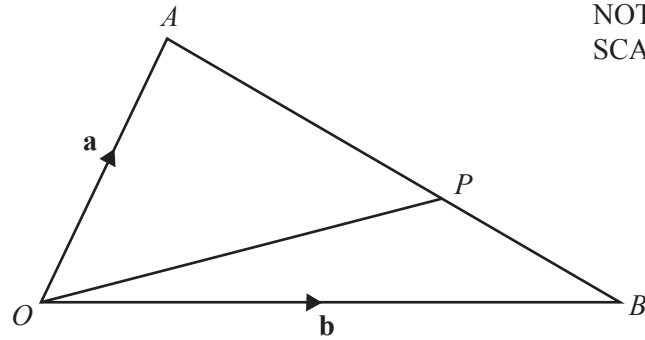

The point P divides AB in the ratio $3 : 2$.

$\vec{OA} = \mathbf{a}$ and $\vec{OB} = \mathbf{b}$.

(a) Write each of these vectors in terms of \mathbf{a} and/or \mathbf{b} , giving each answer in its simplest form.

(i) \vec{AB}

$\vec{AB} = \dots\dots\dots$ [1]

(ii) \vec{OP}

$\vec{OP} = \dots\dots\dots$ [2]

(b) The point Q is such that $\vec{OQ} = \frac{5}{3}\vec{OP}$.

(i) Write \vec{BQ} , in terms of \mathbf{a} and/or \mathbf{b} , in its simplest form.

$\vec{BQ} = \dots\dots\dots$ [2]

(ii) Use your answer to **part (b)(i)** to explain why OA and BQ are parallel.

$\dots\dots\dots$ [1]

14 A is the point $(1, 9)$ and B is the point $(7, 1)$.

(a) Find the length of AB .

..... [3]

(b) Find the co-ordinates of the midpoint of AB .

(.....,)[2]

(c) B is the reflection of A in the line L .

Find the equation of the line L .

..... [4]

Permission to reproduce items where third-party owned material protected by copyright is included has been sought and cleared where possible. Every reasonable effort has been made by the publisher (UCLES) to trace copyright holders, but if any items requiring clearance have unwittingly been included, the publisher will be pleased to make amends at the earliest possible opportunity.

To avoid the issue of disclosure of answer-related information to candidates, all copyright acknowledgements are reproduced online in the Cambridge International Examinations Copyright Acknowledgements Booklet. This is produced for each series of examinations and is freely available to download at www.cie.org.uk after the live examination series.

Cambridge International Examinations is part of the Cambridge Assessment Group. Cambridge Assessment is the brand name of University of Cambridge Local Examinations Syndicate (UCLES), which is itself a department of the University of Cambridge.