

CANDIDATE
NAME

CENTRE
NUMBER

| | | | | |
|--|--|--|--|--|
| | | | | |
|--|--|--|--|--|

CANDIDATE
NUMBER

| | | | |
|--|--|--|--|
| | | | |
|--|--|--|--|

x
8
3
9
8
4
2
2
7
1
6
x

CAMBRIDGE INTERNATIONAL MATHEMATICS

0607/41

Paper 4 (Extended)

May/June 2016

2 hours 15 minutes

Candidates answer on the Question Paper.

Additional Materials: Geometrical Instruments
 Graphics Calculator

READ THESE INSTRUCTIONS FIRST

Write your Centre number, candidate number and name on all the work you hand in.

Write in dark blue or black pen.

Do not use staples, paper clips, glue or correction fluid.

You may use an HB pencil for any diagrams or graphs.

DO NOT WRITE IN ANY BARCODES.

Answer **all** the questions.

Unless instructed otherwise, give your answers exactly or correct to three significant figures as appropriate.

Answers in degrees should be given to one decimal place.

For π , use your calculator value.

You must show all the relevant working to gain full marks and you will be given marks for correct methods, including sketches, even if your answer is incorrect.

The number of marks is given in brackets [] at the end of each question or part question.

The total number of marks for this paper is 120.

This document consists of **20** printed pages.

Formula List

For the equation $ax^2 + bx + c = 0$ $x = \frac{-b \pm \sqrt{b^2 - 4ac}}{2a}$

Curved surface area, A , of cylinder of radius r , height h . $A = 2\pi rh$

Curved surface area, A , of cone of radius r , sloping edge l . $A = \pi rl$

Curved surface area, A , of sphere of radius r . $A = 4\pi r^2$

Volume, V , of pyramid, base area A , height h . $V = \frac{1}{3}Ah$

Volume, V , of cylinder of radius r , height h . $V = \pi r^2 h$

Volume, V , of cone of radius r , height h . $V = \frac{1}{3}\pi r^2 h$

Volume, V , of sphere of radius r . $V = \frac{4}{3}\pi r^3$

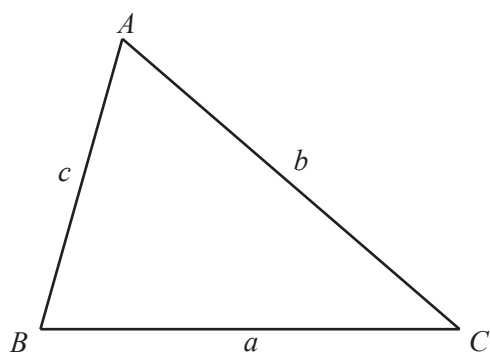

$$\frac{a}{\sin A} = \frac{b}{\sin B} = \frac{c}{\sin C}$$

$$a^2 = b^2 + c^2 - 2bc \cos A$$

$$\text{Area} = \frac{1}{2}bc \sin A$$

Answer **all** the questions.

- 1 (a) Annelise buys a car that is one year old for \$13 600.
The value of this car has reduced by 15% of the value when it was new.

(i) Calculate the value of the car when it was new.

\$ [3]

- (ii) After the first year the car reduces in value by 11% each year for the next 3 years.

Calculate the value of the car after these 3 years.

\$ [3]

- (b) Boris buys a car for \$23 000.
The value of this car reduces by 8% each year.

Find the number of complete years it takes for the value of the car to fall below \$11 500.

..... [3]

- 2 The frequency of a radio wave, f , is inversely proportional to the wavelength, L metres. A radio station broadcasts on a frequency of 93.7 and a wavelength of 3.2 m.

(a) Find a formula for f , in terms of L , writing any constants correct to 3 significant figures.

$$f = \dots\dots\dots [3]$$

(b) Chat Radio broadcasts with a wavelength of 2.8 m.

Find the frequency of Chat Radio.

$$\dots\dots\dots [1]$$

(c) Allsports Radio broadcasts with a frequency of 0.35 .

Find the wavelength of Allsports Radio.

$$\dots\dots\dots \text{ m } [2]$$

3

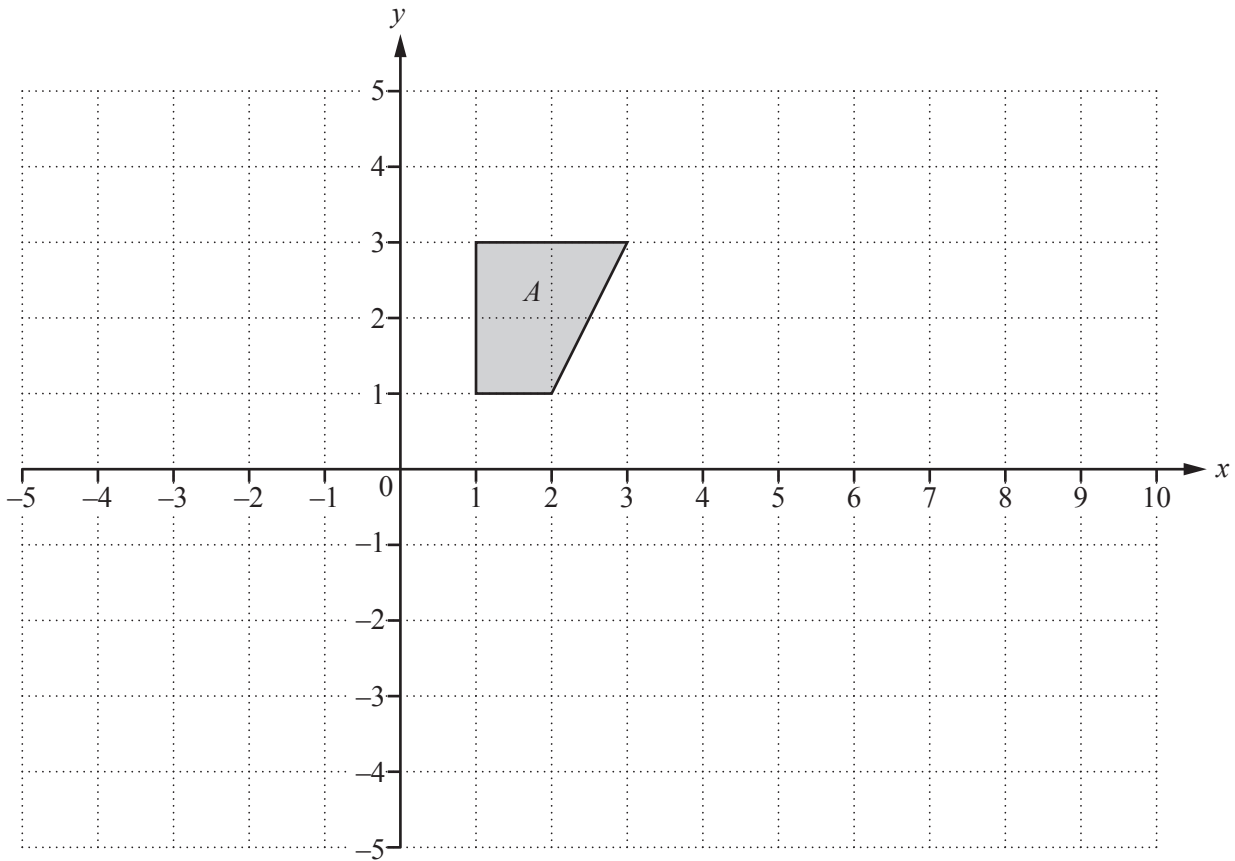

(a) (i) Draw the image of quadrilateral *A* after it has been reflected in the *y*-axis and then rotated through 90° anti-clockwise about the origin. [3]

(ii) Describe fully the **single** transformation equivalent to reflection in the *y*-axis followed by rotation 90° anti-clockwise about the origin.

.....
..... [2]

(b) (i) Draw the image of quadrilateral *A* after a stretch, factor 3 with the *y*-axis invariant. Label the image *B*. [2]

(ii) Describe fully the **single** transformation that maps the quadrilateral *B* back onto quadrilateral *A*.

.....
..... [2]

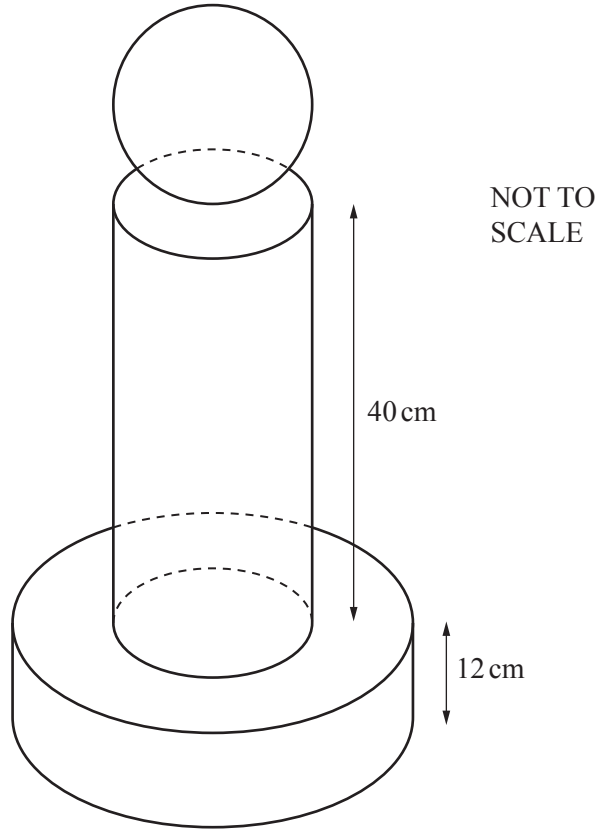

The diagram shows a solid trophy for a football tournament.
The sphere on the top has a radius of 15 cm.
The sphere rests on a cylinder with the same radius as the sphere and height 40 cm.
The base is a cylinder with radius 25 cm and height 12 cm.

(a) Calculate the volume of the trophy.

.....cm³ [4]

- (b) The mass of the trophy is 15 kg.
Each member of the winning team receives a model of the trophy made from the same material.
The model is similar to the real trophy and one-fifth of the height.

(i) Calculate the total height of each model trophy.

..... cm [1]

(ii) Calculate the mass, in grams, of each model trophy.

..... g [3]

- 5 In Kim's game a player looks at a fixed number of objects on a tray for a length of time, t seconds. The player is then tested to find how many objects they remember.

The table shows the results for 10 players.

| | | | | | | | | | | |
|---------------------------|----|----|----|----|----|----|----|-----|-----|-----|
| Time in seconds (t) | 30 | 40 | 50 | 60 | 70 | 80 | 90 | 100 | 110 | 120 |
| Number of objects (n) | 8 | 10 | 15 | 12 | 16 | 20 | 18 | 23 | 19 | 25 |

- (a) Complete the scatter diagram.
The first six points have been plotted for you.

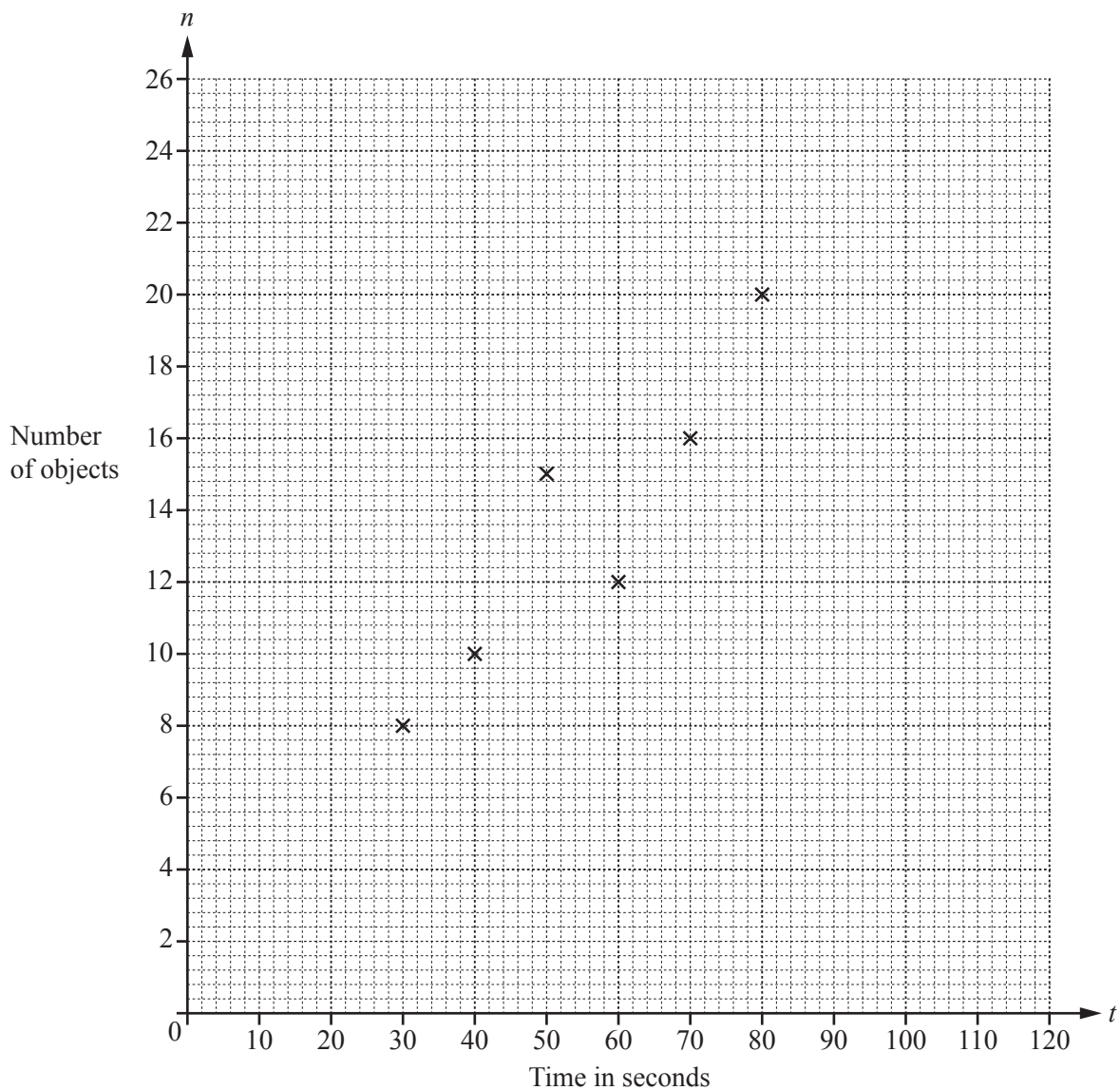

[2]

- (b) What type of correlation is shown by the scatter diagram?

..... [1]

(c) (i) Calculate the mean time.

.....s [1]

(ii) Calculate the mean number of objects.

..... [1]

(d) (i) Find the equation of the regression line.
Give your answer in the form $n = mt + c$.

$n =$ [2]

(ii) Errol looks at the tray for 85 seconds.

Use your equation to estimate the number of objects he remembers.

..... [1]

- 6 (a) These are the first four terms of a sequence.

5 8 11 14

Write down an expression in terms of n for the n th term, s_n , of the sequence.

$s_n =$ [2]

- (b) The n th term, t_n , of another sequence is $2n^2 + n - 6$.

Write down the first four terms of this sequence.

.....,,, [2]

- (c) The n th term of a third sequence, u_n , is given by

$$u_n = \frac{t_n}{n+2}$$

Find an expression for u_n , in terms of n , giving your answer in its simplest form.

$u_n =$ [3]

- (d) The n th term of a fourth sequence is given by $s_n + u_n$.

Is 501 a term of this fourth sequence?
Give your reasons.

..... because
..... [2]

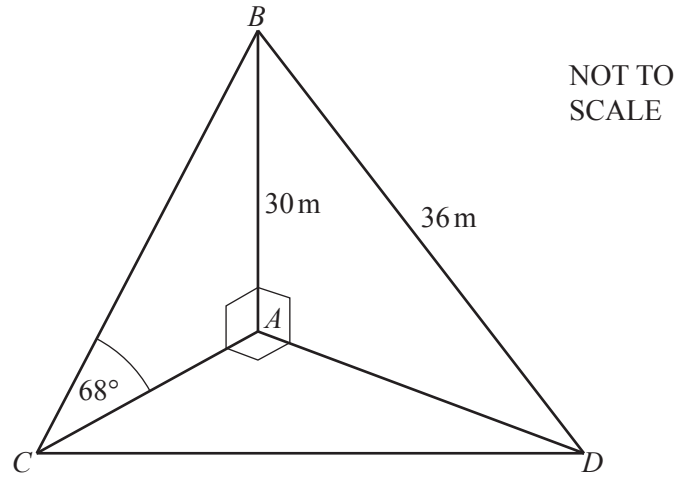

AB is a vertical tower of height 30 m.
 BC and BD are straight wires attached to B .
 A , C and D are on horizontal ground with C due west of D .
 Angle $BCA = 68^\circ$ and $BD = 36$ m.

(a) Calculate AD .

$AD = \dots\dots\dots$ m [3]

(b) Calculate AC and show that it rounds to 12.1 m, correct to 3 significant figures.

[3]

(c) Calculate the bearing of A from D .

$\dots\dots\dots$ [3]

8 (a)

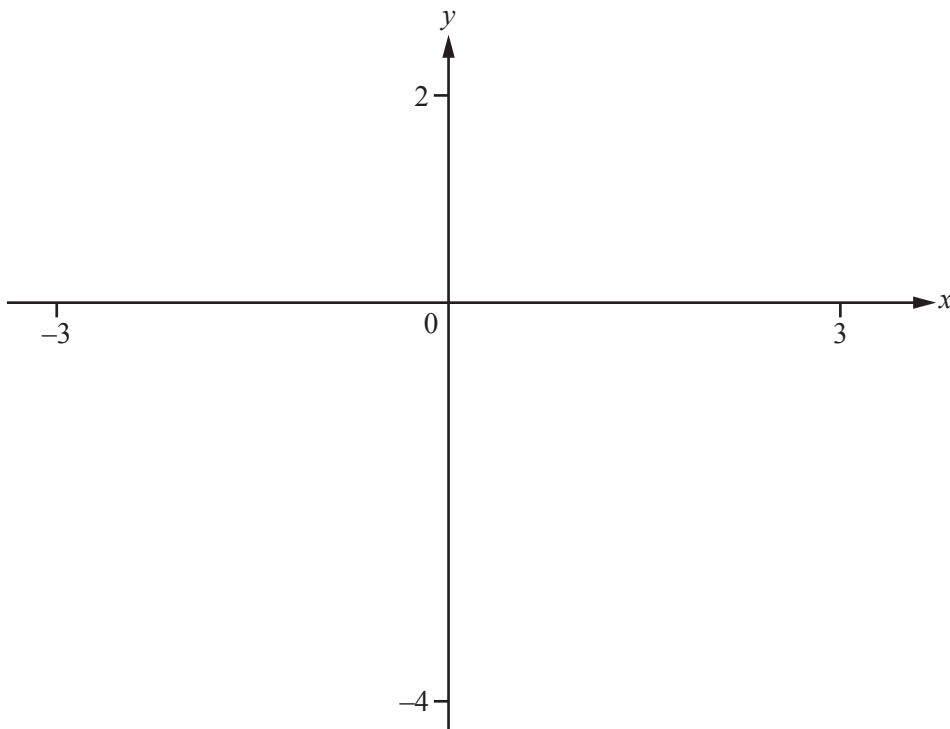

$$f(x) = \log(1 + 2x + x^2)$$

(i) On the diagram, sketch the graph of $y = f(x)$ for values of x between -3 and 3 . [2]

(ii) Solve $f(x) = 0$.

$x = \dots\dots\dots$ or $x = \dots\dots\dots$ [2]

(iii) Write down the equation of the asymptote to the graph of $y = f(x)$.

$\dots\dots\dots$ [1]



- (b) (i) On this diagram, sketch the graph of $y = 2 \log(1+x)$ for values of x between -3 and 3 .

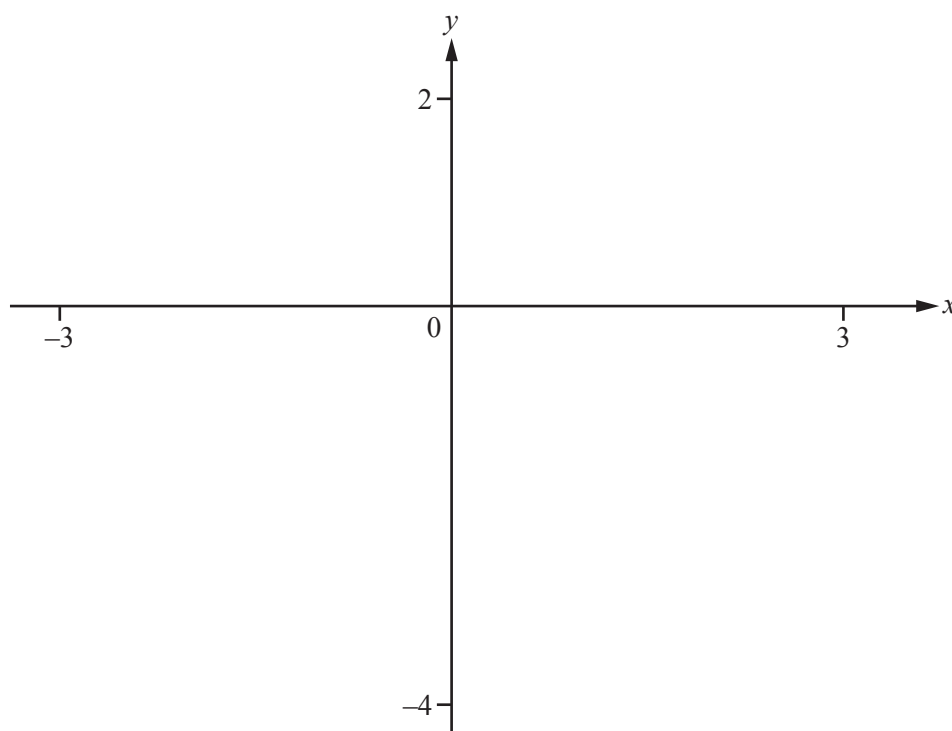

[2]

- (ii) Describe a similarity between the graphs in **part (a)(i)** and **part (b)(i)**.

.....
 [1]

- (iii) Explain the differences between the graphs in **part (a)(i)** and **part (b)(i)**.

.....
 [2]

9 Hamish travels from Perth to London by train.
During the journey, the train stops in Edinburgh.

- (a) The distance from Perth to Edinburgh is 65 km.
The train travels at an average speed of 48.75 km/h for this part of the journey.

Find the time taken to travel from Perth to Edinburgh.
Give your answer in hours and minutes.

..... h min [3]

- (b) The average speed for the whole journey from Perth to London is 119.5 km/h.
The distance from Edinburgh to London is 632 km.

Find the average speed for the journey from Edinburgh to London.

..... km/h [5]

- (c) During the journey, the train travels through a tunnel of length 800 m.
The train travels through this tunnel at 120 km/h.
The train is 130 m long.

Calculate the time taken for the train to pass completely through the tunnel.
Give your answer in seconds.

..... s [3]

10 A is the point $(-2, -1)$ and B is the point $(6, 3)$.

(a) Calculate $|\vec{AB}|$.

..... [3]

(b) The point P has co-ordinates (x, y) and $PA = PB$.

Show that $2x + y = 5$.

[5]

(c) If P is also on the line $y = x$, find the co-ordinates of P .

(.....,) [2]

11

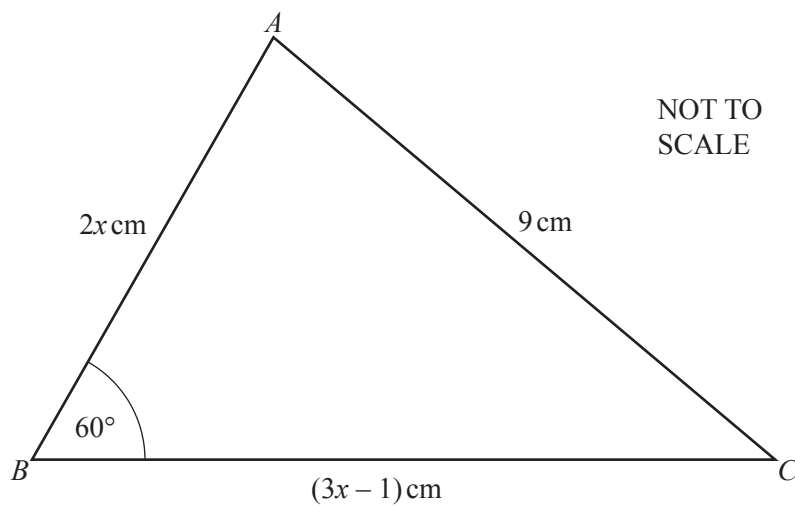

- (a) Use the cosine rule to show that $7x^2 - 4x - 80 = 0$.

[4]

- (b) (i) Solve the equation $7x^2 - 4x - 80 = 0$.
Show all your working.

$x = \dots\dots\dots$ or $x = \dots\dots\dots$ [3]

- (ii) Find the length of AB and the length of BC .

$AB = \dots\dots\dots$ cm

$BC = \dots\dots\dots$ cm [2]

- (c) Find the area of triangle ABC .

$\dots\dots\dots$ cm² [2]

12 The table shows the masses in grams of 200 eggs.

| Mass (m grams) | $45 < m \leq 50$ | $50 < m \leq 55$ | $55 < m \leq 60$ | $60 < m \leq 65$ | $65 < m \leq 70$ | $70 < m \leq 75$ | $75 < m \leq 80$ |
|-------------------|------------------|------------------|------------------|------------------|------------------|------------------|------------------|
| Frequency | 5 | 19 | 34 | 58 | 46 | 29 | 9 |

(a) Calculate an estimate of the mean mass.

..... g [2]

(b) On the grid, complete the cumulative frequency curve for the information in the table.

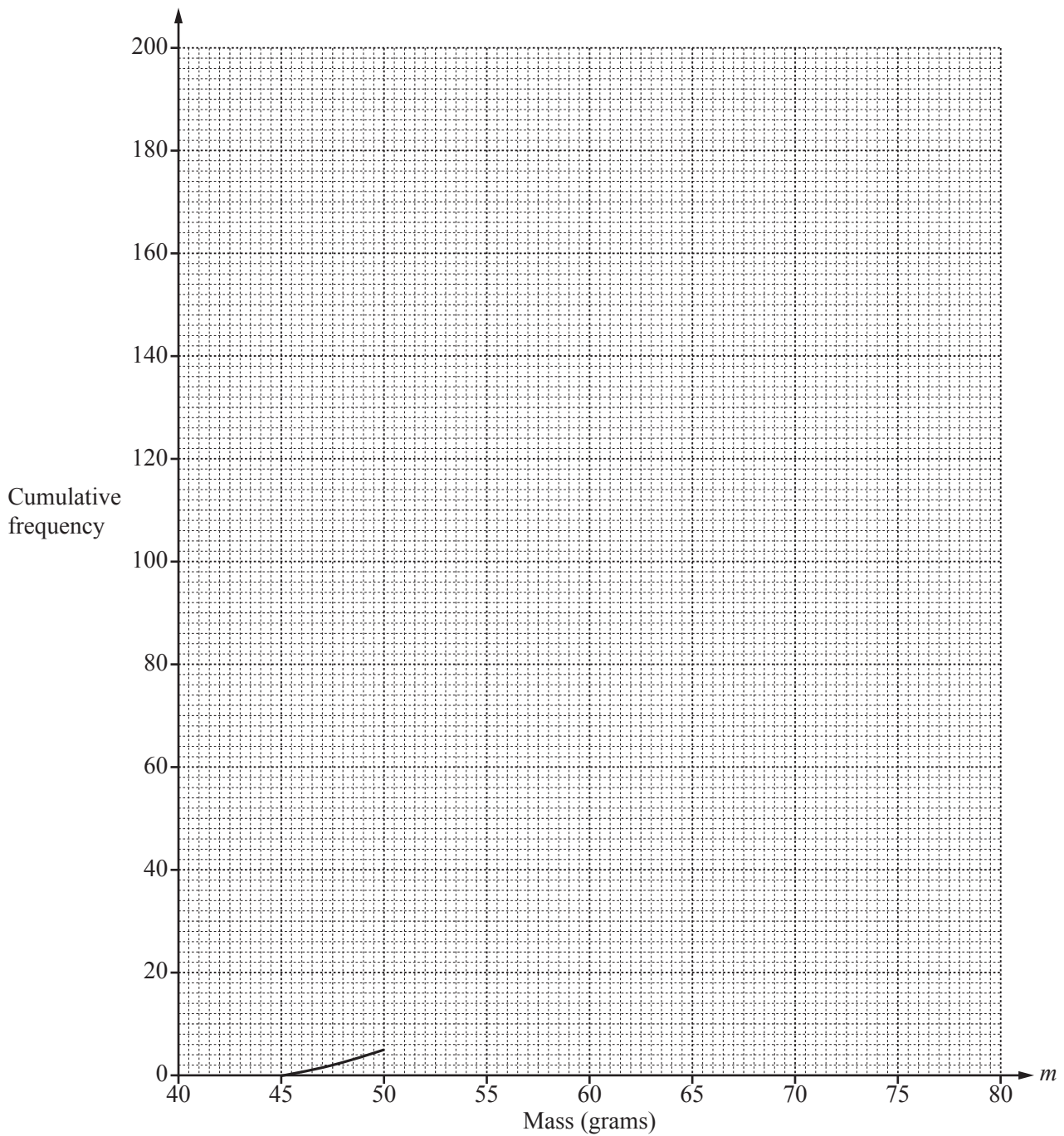

[5]

(c) Use your graph to find

(i) the median mass,

..... g [1]

(ii) the interquartile range.

..... g [2]

(d) This table shows how the eggs are graded according to their mass.

| Size | Small | Medium | Large | Very Large |
|-------------------|-------------|------------------|------------------|------------|
| Mass (m grams) | $m \leq 53$ | $53 < m \leq 63$ | $63 < m \leq 75$ | $m > 75$ |

(i) An egg is chosen at random from the 200 eggs.

Estimate the probability that the egg is Small.

..... [1]

(ii) Two eggs are chosen from the 200 eggs.

Find the probability that both are Very Large.

..... [2]

Question 13 is printed on the next page.

13 (a) $f(x) = 5 - 2x$

(i) Solve $\frac{1}{f(x)} = 2$.

$x = \dots\dots\dots$ [2]

(ii) Find and simplify $f(f(x))$.

$\dots\dots\dots$ [2]

(iii) Find $f^{-1}(x)$.

$f^{-1}(x) = \dots\dots\dots$ [2]

(b) $g(x)$ is a function with an inverse function $g^{-1}(x)$.

Write down the value of $g(g^{-1}(3))$.

$\dots\dots\dots$ [1]

Permission to reproduce items where third-party owned material protected by copyright is included has been sought and cleared where possible. Every reasonable effort has been made by the publisher (UCLES) to trace copyright holders, but if any items requiring clearance have unwittingly been included, the publisher will be pleased to make amends at the earliest possible opportunity.

To avoid the issue of disclosure of answer-related information to candidates, all copyright acknowledgements are reproduced online in the Cambridge International Examinations Copyright Acknowledgements Booklet. This is produced for each series of examinations and is freely available to download at www.cie.org.uk after the live examination series.

Cambridge International Examinations is part of the Cambridge Assessment Group. Cambridge Assessment is the brand name of University of Cambridge Local Examinations Syndicate (UCLES), which is itself a department of the University of Cambridge.