



**Cambridge International Examinations**  
Cambridge International General Certificate of Secondary Education

CANDIDATE NAME

CENTRE NUMBER 

--	--	--	--	--

CANDIDATE NUMBER 

--	--	--	--

\* 1 9 4 8 2 5 5 7 3 7 \*

**CAMBRIDGE INTERNATIONAL MATHEMATICS**

**0607/31**

Paper 3 (Core)

**May/June 2014**

**1 hour 45 minutes**

Candidates answer on the Question Paper.

Additional Materials: Geometrical Instruments  
Graphics Calculator

**READ THESE INSTRUCTIONS FIRST**

Write your Centre number, candidate number and name on all the work you hand in.  
Write in dark blue or black pen.  
Do not use staples, paper clips, glue or correction fluid.  
You may use an HB pencil for any diagrams or graphs.  
**DO NOT WRITE IN ANY BARCODES.**

Answer **all** the questions.  
Unless instructed otherwise, give your answers exactly or correct to three significant figures as appropriate.  
Answers in degrees should be given to one decimal place.  
For  $\pi$ , use your calculator value.  
You must show all the relevant working to gain full marks and you will be given marks for correct methods, including sketches, even if your answer is incorrect.  
The number of marks is given in brackets [ ] at the end of each question or part question.  
The total number of marks for this paper is 96.

This document consists of **16** printed pages.

## Formula List

Area,  $A$ , of triangle, base  $b$ , height  $h$ .

$$A = \frac{1}{2}bh$$

Area,  $A$ , of circle, radius  $r$ .

$$A = \pi r^2$$

Circumference,  $C$ , of circle, radius  $r$ .

$$C = 2\pi r$$

Curved surface area,  $A$ , of cylinder of radius  $r$ , height  $h$ .

$$A = 2\pi rh$$

Curved surface area,  $A$ , of cone of radius  $r$ , sloping edge  $l$ .

$$A = \pi rl$$

Curved surface area,  $A$ , of sphere of radius  $r$ .

$$A = 4\pi r^2$$

Volume,  $V$ , of prism, cross-sectional area  $A$ , length  $l$ .

$$V = Al$$

Volume,  $V$ , of pyramid, base area  $A$ , height  $h$ .

$$V = \frac{1}{3}Ah$$

Volume,  $V$ , of cylinder of radius  $r$ , height  $h$ .

$$V = \pi r^2 h$$

Volume,  $V$ , of cone of radius  $r$ , height  $h$ .

$$V = \frac{1}{3}\pi r^2 h$$

Volume,  $V$ , of sphere of radius  $r$ .

$$V = \frac{4}{3}\pi r^3$$

Answer **all** the questions.

1

21 22 23 24 25 26 27

From the list above, write down

**(a)** a square number,

*Answer(a)* ..... [1]

**(b)** a multiple of 7,

*Answer(b)* ..... [1]

**(c)** a factor of 66,

*Answer(c)* ..... [1]

**(d)** a cube number,

*Answer(d)* ..... [1]

**(e)** a prime number.

*Answer(e)* ..... [1]

---

**2**  $2p + 3q = r$

**(a)** Find  $r$  when  $p = 3.1$  and  $q = 2.5$  .

*Answer(a)*  $r =$  ..... [2]

**(b)** Find  $p$  when  $q = -1$  and  $r = 4$ .

*Answer(b)*  $p =$  ..... [2]

**(c)** Rearrange  $2p + 3q = r$  to make  $q$  the subject.

*Answer(c)*  $q =$  ..... [2]

---

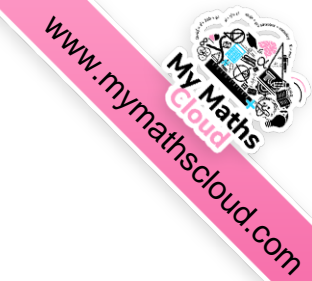

3 (a) 41, 37, 33, 29, 25, .....

Find the next two terms in this sequence.

Answer(a) ..... and ..... [2]

(b) Find  $\sqrt{60}$ .

Give your answer correct to 1 decimal place.

Answer(b) ..... [2]

(c) Write 0.28 as a fraction in its simplest form.

Answer(c) ..... [1]

(d) Divide 504 in the ratio 7 : 2 .

Answer(d) ..... : ..... [2]

(e) Write the following numbers in order, starting with the smallest.

$\frac{1}{8}$        $1.3 \times 10^{-1}$       14%      0.11

Answer(e) ..... , ..... , ..... , ..... [2]  
smallest

4

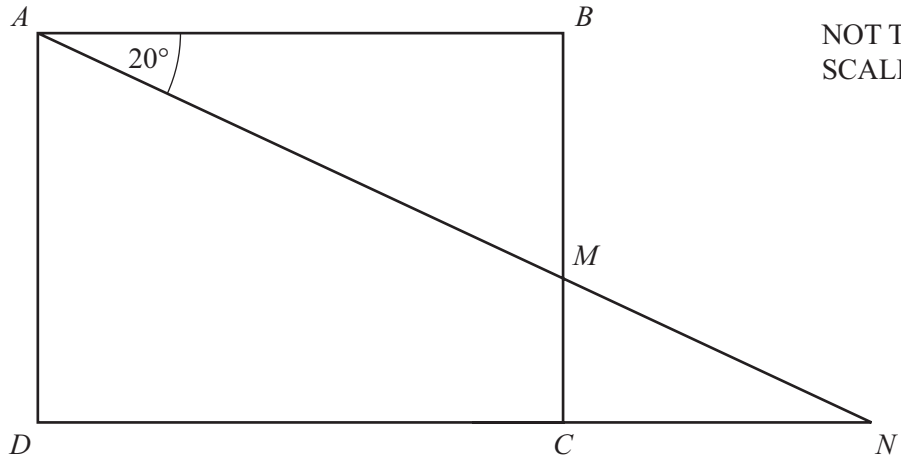

$ABCD$  is a rectangle.

$AMN$  and  $DCN$  are straight lines and angle  $BAM = 20^\circ$ .

Find the size of

(a) angle  $AMB$ ,

Answer(a) ..... [1]

(b) angle  $MNC$ ,

Answer(b) ..... [1]

(c) angle  $BMN$ .

Answer(c) ..... [1]

5 Jeffrey has 30 packets of raisins.

The number of raisins in each packet is shown below.

39 38 41 40 38 39 37 42 38 38  
 39 41 41 40 39 38 37 43 38 39  
 40 40 39 38 41 38 42 43 39 37

(a) Complete the frequency table.

Number of raisins	Frequency
37	3
38	
39	
40	4
41	
42	
43	2

[2]

(b) Complete the bar chart to show this information.

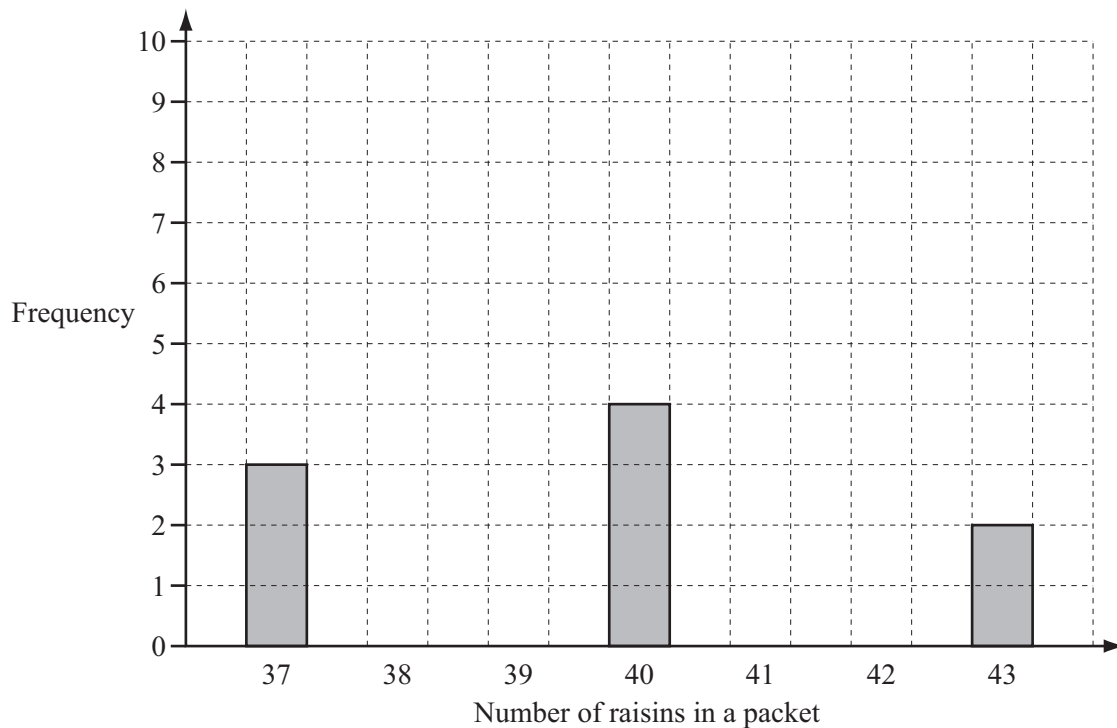

[2]

(c) Find

(i) the range,

*Answer(c)(i)* ..... [1]

(ii) the mode,

*Answer(c)(ii)* ..... [1]

(iii) the median,

*Answer(c)(iii)* ..... [1]

(iv) the mean.

*Answer(c)(iv)* ..... [1]

(d) Jeffrey opens one packet at random.

Find the probability that there are more than 40 raisins in this packet.

*Answer(d)* ..... [1]

---

- 6 Rana gives surfing lessons.  
She charges \$50 per hour.

- (a) Rana works 35 hours each week.

Calculate how much she earns each week.

Answer(a) \$ ..... [1]

- (b) Rana spends \$1300 each week.

Find how much she has left each week.

Answer(b) \$ ..... [1]

- (c) Rana gives 10% of the money she has left to charity and saves the remainder.

- (i) Calculate the amount that Rana gives to charity each week.

Answer(c)(i) \$ ..... [2]

- (ii) Calculate the amount that Rana saves each week.

Answer(c)(ii) \$ ..... [1]

- (d) Rana has 6 weeks holiday each year.  
She does **not** earn any money during her holiday.

Find the amount of money that Rana saves in a year (52 weeks).

Answer(d) \$ ..... [2]



- 7 Max has a die with faces numbered 1 to 6.  
He rolls the die 120 times.  
The pie chart shows the results.

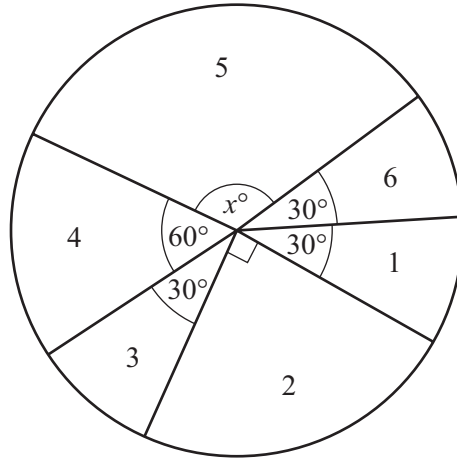

NOT TO SCALE

- (a) Find the value of  $x$ .

Answer(a)  $x =$  ..... [1]

- (b) Find the number of times that Max rolled a 4.

Answer(b) ..... [2]

- (c) Is the die biased? Give a reason for your answer.

Answer(c) ..... because .....  
..... [2]

8

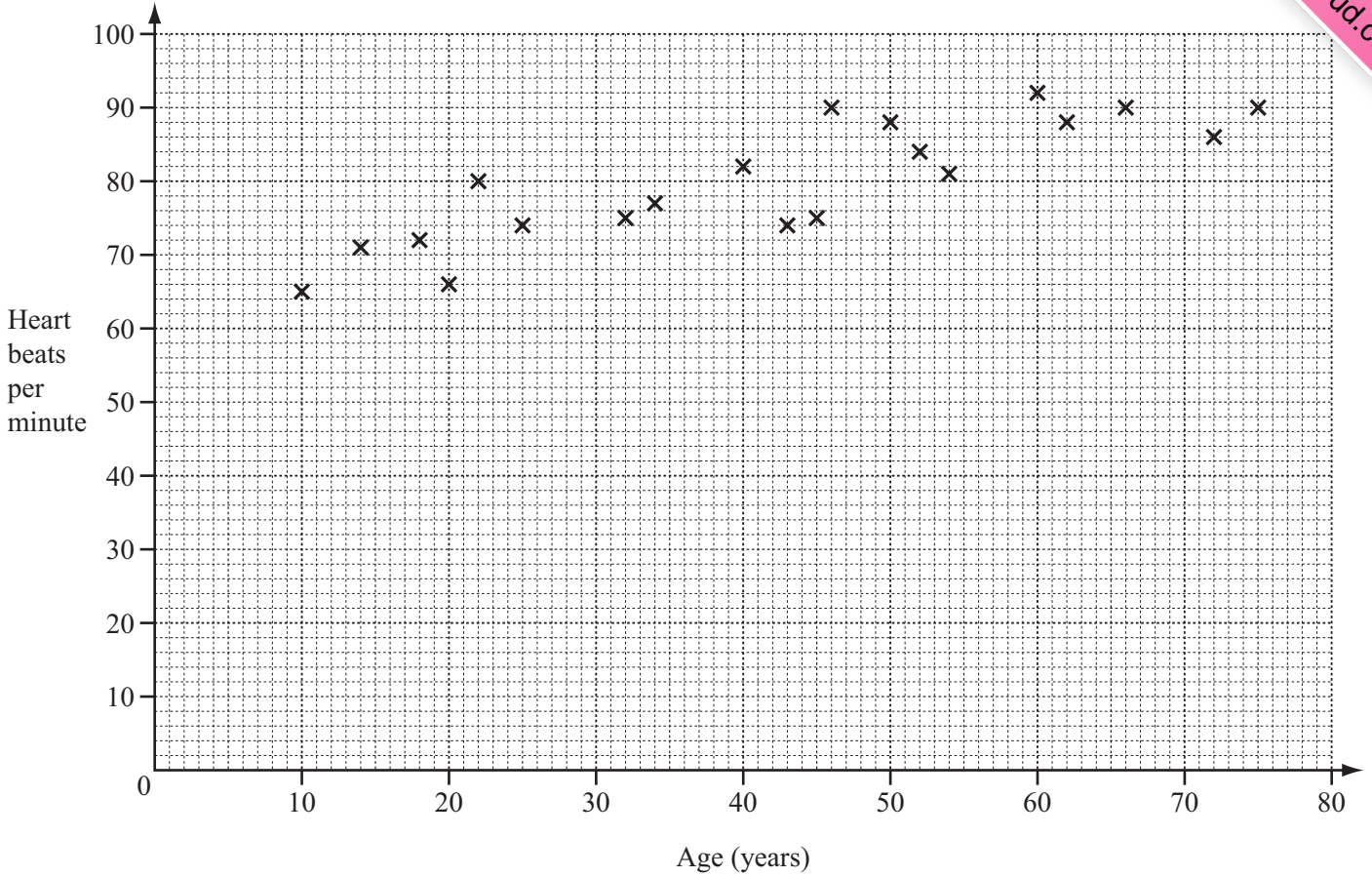

The scatter diagram shows the age, in years, and number of heart beats per minute of 20 people.

(a) Describe the type of correlation.

Answer(a) ..... [1]

(b) The mean age of the twenty people is 42 and the mean number of heart beats per minute is 80.

Plot this point on the scatter diagram. [1]

(c) Draw the line of best fit by eye.

[2]

(d) Heidi is 28 years old.

Estimate Heidi's number of heart beats per minute.

Answer(d) ..... [1]

9 The distance between Mumbai and Ahmedabad is 494 kilometres.

(a) An express train takes 6.5 hours for the journey.

Find the average speed of the train in kilometres per hour.

Answer(a) ..... km/h [1]

(b) A slow train travels at an average speed of 45 kilometres per hour.

Find the time that this train takes to travel the 494 kilometres.

Give your answer correct to the nearest minute.

Answer(b) ..... h ..... min [2]

10 Marcina has a box containing 20 mathematical shapes.

$S$  is the set of shapes with equal sides.

$A$  is the set of shapes with equal angles.

$n(S) = 8$ ,  $n(A) = 7$  and  $n(S \cap A) = 3$ .

(a) Complete the Venn diagram.

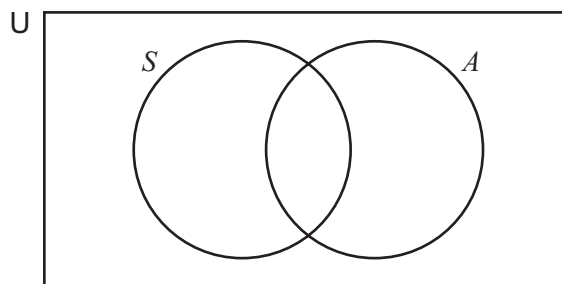

[2]

(b) Write down the number of shapes that do not have equal sides or equal angles.

Answer(b) ..... [2]

(c) Write down the mathematical name for a shape that could be in the set  $S \cap A$ .

Answer(c) ..... [1]

(d) Shade the region  $A \cap S'$ .

[1]

- 11 The cost of a dress is  $\$d$ .  
The cost of a pair of shoes is  $\$s$ .

Adel buys 2 dresses and 4 pairs of shoes for  $\$1100$ .  
So,  $2d + 4s = 1100$ .

- (a) Carey buys 5 dresses and 4 pairs of shoes for  $\$1850$ .

Write this as an equation in terms of  $d$  and  $s$ .

*Answer(a)* ..... [1]

- (b) Solve the equations to find the cost of one dress and the cost of one pair of shoes.

*Answer(b)* Dress \$ .....

Pair of shoes \$ ..... [2]

12

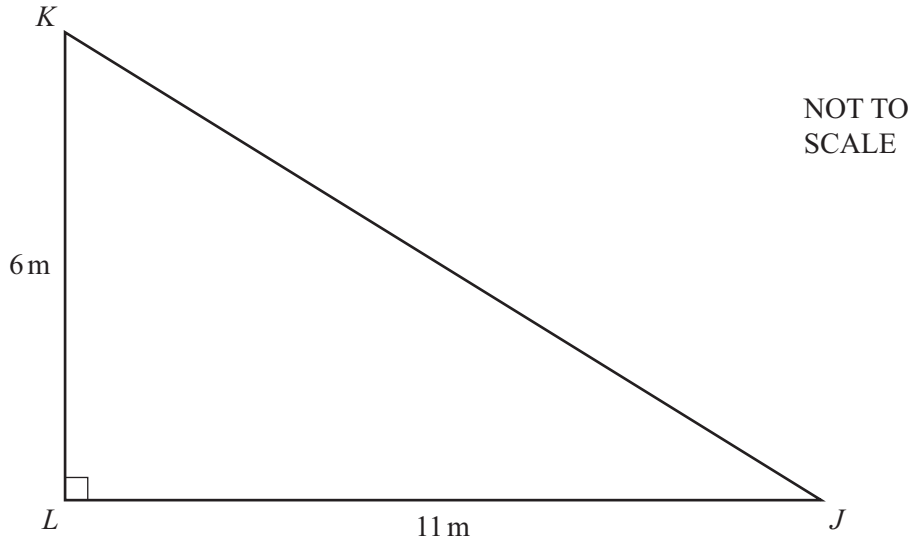

(a) Find the length  $JK$ .

Answer(a) ..... m [2]

(b) Use trigonometry to calculate angle  $KJL$ .

Answer(b) ..... [2]

13

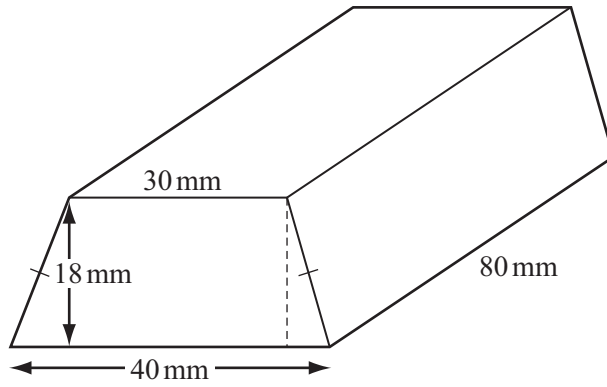

NOT TO SCALE

A gold bar is in the shape of a prism.  
The cross-section is a trapezium.

(a) Find the area of the cross-section of the gold bar.

Answer(a) ..... mm<sup>2</sup> [3]

(b) Find the total surface area of the gold bar.

Answer(b) ..... mm<sup>2</sup> [5]

(c) Find the volume of the gold bar.

Answer(c) ..... mm<sup>3</sup> [1]

(d) Write your answer to **part (c)** in cm<sup>3</sup>.

Answer(d) ..... cm<sup>3</sup> [1]

(e) The gold bar is melted and made into a cylinder with radius 2 cm.

Calculate the height of this cylinder.

Answer(e) ..... cm [2]

14

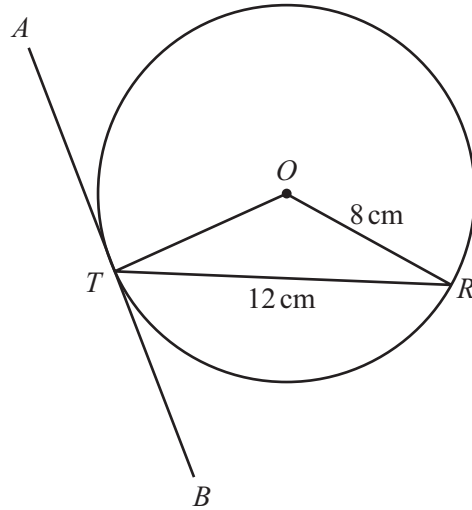

NOT TO SCALE

The diagram shows a circle, centre  $O$ , radius 8 cm.  
Chord  $RT$  is 12 cm and  $ATB$  is a tangent to the circle at  $T$ .

(a) Use trigonometry to calculate angle  $ROT$ .

Answer(a) ..... [3]

(b) Find angle  $RTB$ .

Answer(b) ..... [2]

(c) Calculate the length of arc  $RT$ .

Answer(c) ..... cm [2]

Question 15 is printed on the next page.

15

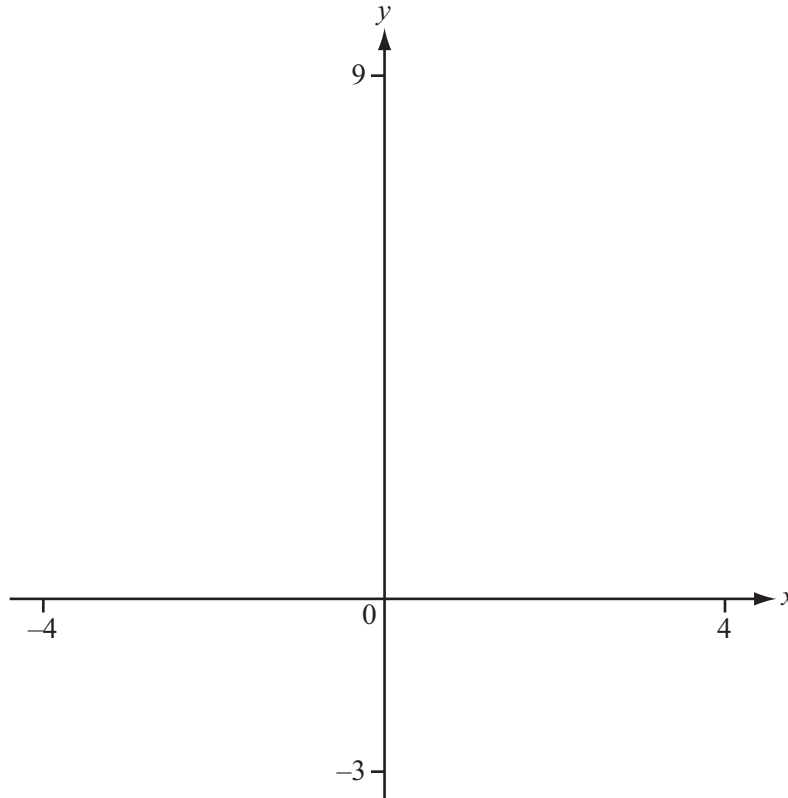

$$f(x) = 3 + \frac{x^2}{(x-1)}$$

(a) On the diagram, sketch the graph of  $y = f(x)$  between  $x = -4$  and  $x = 4$ . [4]

(b) Find the co-ordinates of the local minimum point.

Answer(b) ( ..... , ..... ) [1]

(c) Write down the equation of the vertical asymptote.

Answer(c) ..... [1]

(d) Write down the range of  $f(x)$  for  $x < 1$ .

Answer(d) ..... [2]

(e)  $g(x) = 4x + 1$   
On the diagram, sketch the graph of  $y = g(x)$ . [2]

(f) Find the  $x$  co-ordinates of the points of intersection of  $y = f(x)$  and  $y = g(x)$ .

Answer(f)  $x =$  .....  
 $x =$  ..... [2]

Permission to reproduce items where third-party owned material protected by copyright is included has been sought and cleared where possible. Every reasonable effort has been made by the publisher (UCLES) to trace copyright holders, but if any items requiring clearance have unwittingly been included, the publisher will be pleased to make amends at the earliest possible opportunity.

Cambridge International Examinations is part of the Cambridge Assessment Group. Cambridge Assessment is the brand name of University of Cambridge Local Examinations Syndicate (UCLES), which is itself a department of the University of Cambridge.