



Cambridge International Examinations
Cambridge Ordinary Level

CANDIDATE
NAME

CENTRE
NUMBER

| | | | | | |
|--|--|--|--|--|--|
| | | | | | |
|--|--|--|--|--|--|

CANDIDATE
NUMBER

| | | | | |
|--|--|--|--|--|
| | | | | |
|--|--|--|--|--|



MATHEMATICS (SYLLABUS D)

4024/22

Paper 2

October/November 2017

2 hours 30 minutes

Candidates answer on the Question Paper.

Additional Materials: Geometrical instruments
 Electronic calculator

READ THESE INSTRUCTIONS FIRST

Write your Centre number, candidate number and name on all the work you hand in.
Write in dark blue or black pen.
You may use an HB pencil for any diagrams or graphs.
Do not use staples, paper clips, glue or correction fluid.
DO NOT WRITE IN ANY BARCODES.

Section A

Answer **all** questions.

Section B

Answer any **four** questions.

If working is needed for any question it must be shown in the space below that question.
Omission of essential working will result in loss of marks.
You are expected to use an electronic calculator to evaluate explicit numerical expressions.
If the degree of accuracy is not specified in the question, and if the answer is not exact, give the answer to three significant figures. Give answers in degrees to one decimal place.
For π , use either your calculator value or 3.142, unless the question requires the answer in terms of π .

The number of marks is given in brackets [] at the end of each question or part question.
The total of the marks for this paper is 100.

This document consists of **23** printed pages and **1** blank page.

Section A [52 marks]

Answer **all** questions in this section.

- 1 (a) Sara buys a new car.
The cash price of the car is \$4500.
She can pay for the car using option A or option B.

| Option A |
|---|
| Pay $\frac{1}{5}$ of the cash price then 12 monthly payments of \$340 |

| Option B |
|---|
| Pay 12% of the cash price then 24 monthly payments of \$195 |

Which option is cheaper and by how much?

Answer Option is cheaper by \$ [4]

- (b) Sara's car uses 5.2 litres of petrol for each 100 km she drives.
Petrol costs \$0.85 per litre.
Sara drives 240 km.

Calculate the cost of the petrol used for this journey.
Give your answer correct to the nearest cent.

Answer \$ [3]

- (c) Sara pays a total of \$322 for her car insurance.
This total is made up of a basic charge plus 15% sales tax.

Calculate the amount of sales tax that Sara pays.

Answer \$ [3]

- 2 A company asked their employees how long they took to travel to work one day. The table summarises the times for 120 employees.

| Time (t minutes) | $0 < t \leq 20$ | $20 < t \leq 40$ | $40 < t \leq 60$ | $60 < t \leq 80$ | $80 < t \leq 100$ |
|---------------------|-----------------|------------------|------------------|------------------|-------------------|
| Frequency | 12 | 28 | 45 | 22 | 13 |

- (a) (i) Complete the cumulative frequency table below.

| Time (t minutes) | $t \leq 0$ | $t \leq 20$ | $t \leq 40$ | $t \leq 60$ | $t \leq 80$ | $t \leq 100$ |
|----------------------|------------|-------------|-------------|-------------|-------------|--------------|
| Cumulative frequency | 0 | | | | | 120 |

[1]

- (ii) On the grid, draw a smooth cumulative frequency curve to represent these results.

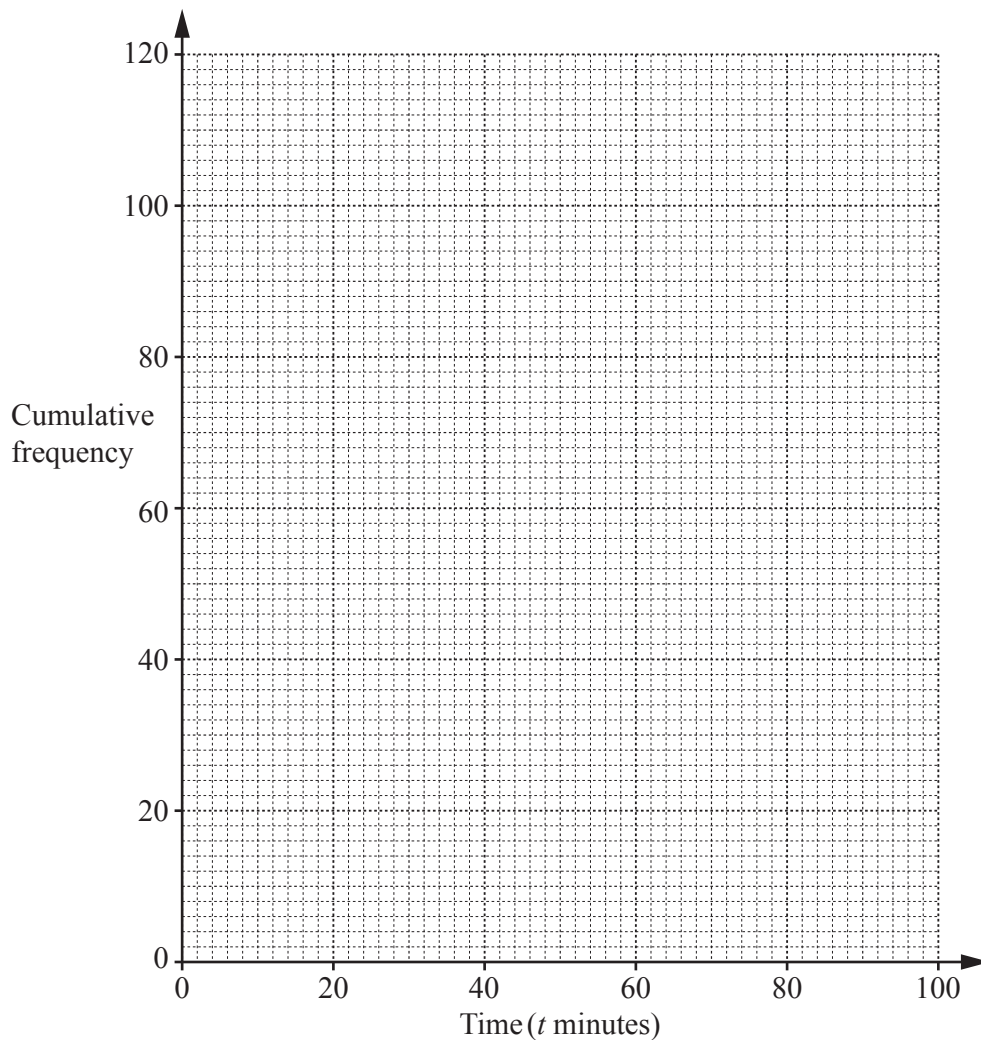

[2]

(b) Use your curve to estimate

(i) the median time,

Answer minutes [1]

(ii) the interquartile range of the times.

Answer minutes [2]

(c) Calculate an estimate of the mean time taken for the employees to travel to work.

Answer minutes [3]

- 3 Anya makes T-shirts.
The matrix, \mathbf{M} , shows the number of T-shirts of different types she makes in one week.

$$\mathbf{M} = \begin{array}{ccc} \text{Small} & \text{Medium} & \text{Large} \\ \left(\begin{array}{ccc} 10 & 25 & 30 \\ 20 & 40 & 25 \end{array} \right) \begin{array}{l} \text{Men} \\ \text{Women} \end{array} \end{array}$$

- (a) Anya sells all of these T-shirts to a shop.
She charges \$5 for each small T-shirt, \$6 for each medium T-shirt and \$8 for each large T-shirt.

Represent these amounts in a 3×1 column matrix \mathbf{N} .

Answer $\mathbf{N} =$ [1]

- (b) (i) Work out $\mathbf{P} = \mathbf{MN}$.

Answer $\mathbf{P} =$ [2]

- (ii) Explain what the elements in matrix \mathbf{P} represent.

Answer

..... [1]

- (c) The shopkeeper sells all sizes of men's T-shirts at \$10 each.
He sells all sizes of women's T-shirts at \$9.50 each.
He sells all of these T-shirts.

(i) Work out $(10 \quad 9.50) \begin{pmatrix} 10 & 25 & 30 \\ 20 & 40 & 25 \end{pmatrix}$.

Answer [2]

- (ii) Work out the percentage profit the shopkeeper makes when he sells all of the T-shirts.

Answer% [3]

- 4 (a) Triangle A is shown on the grid.

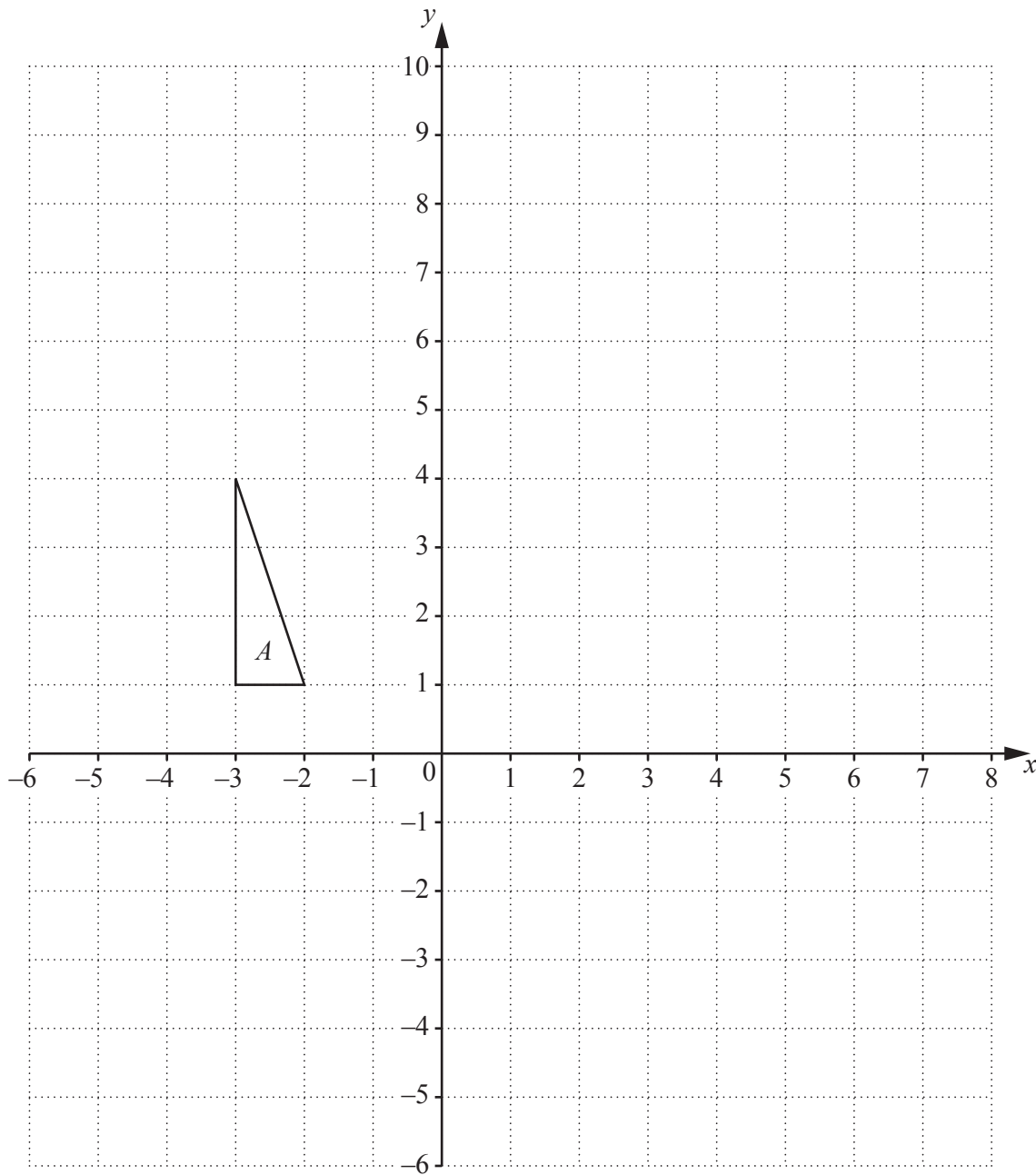

- (i) Triangle A is mapped onto triangle B by a translation of $\begin{pmatrix} 7 \\ -5 \end{pmatrix}$.

Draw and label triangle B on the grid.

[2]

- (ii) Triangle A is mapped onto triangle C by an enlargement scale factor -2 , centre $(-1, 2)$.

Draw and label triangle C on the grid.

[2]

(b) Triangle P is shown on the grid.

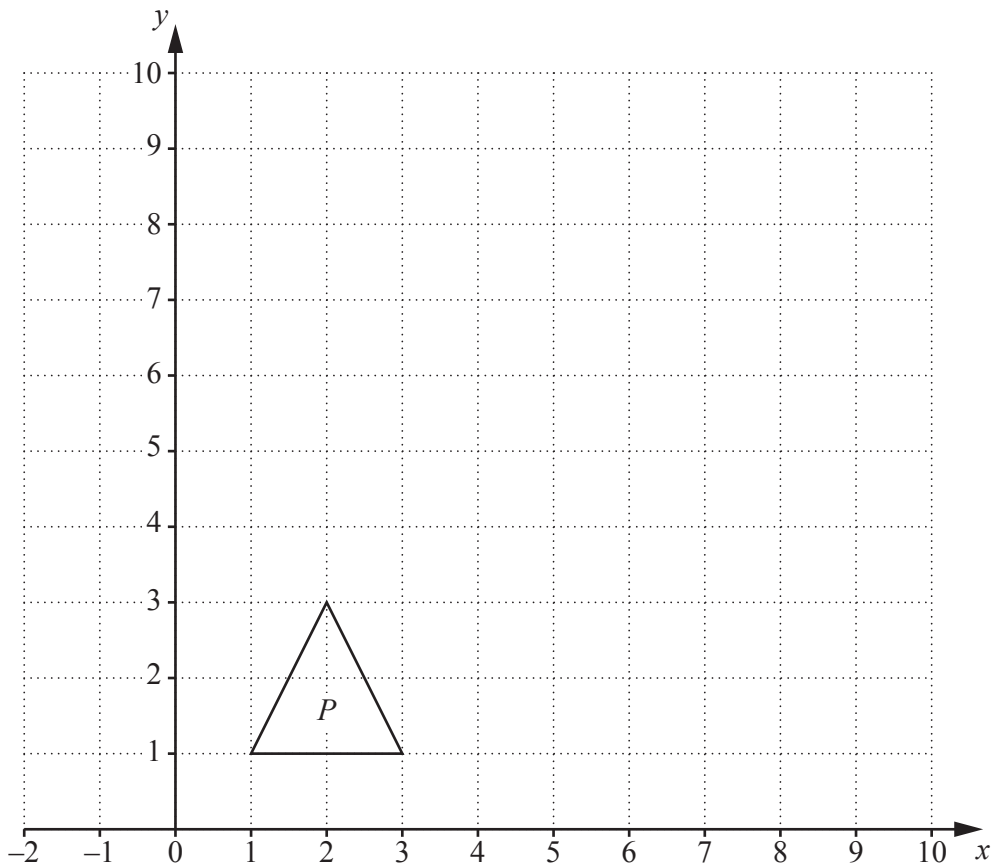

The stretch S is represented by the matrix $\begin{pmatrix} 3 & 0 \\ 0 & 1 \end{pmatrix}$.

Triangle P is mapped onto triangle Q by the stretch S .

(i) On the grid above, draw and label triangle Q .

[2]

(ii) Describe fully the stretch S .

.....
 [2]

- 5 (a) Express as a single fraction in its simplest form $\frac{4}{x-2} - \frac{5}{x+1}$.

Answer [2]

- (b) Solve $2x(x+1) = 3(4-x)$.

Answer $x =$ or [3]

- (c) Anil and Yasmin buy some pens and notebooks from the same shop.

Anil buys 3 pens and 2 notebooks for \$4.80 .

Yasmin buys 5 pens and 4 notebooks for \$9.00 .

- (i) Form a pair of simultaneous equations to represent this information.

[1]

- (ii) Solve the simultaneous equations to find the cost of a pen and the cost of a notebook.

Answer Cost of pen = \$

Cost of notebook = \$[3]

6 (a) $\mathcal{E} = \{x : x \text{ is an integer and } 10 \leq x \leq 20\}$

$A = \{x : x \text{ is an odd number}\}$

$B = \{x : x \text{ is a multiple of } 5\}$

(i) Find $n(A \cap B)$.

Answer [1]

(ii) Find $A' \cup B$.

Answer [1]

(iii) A number, r , is chosen at random from \mathcal{E} .

Find the probability that $r \in A \cup B$.

Answer [1]

(b) In a survey, 40 people were asked what they had read that day.

- A total of 10 people had read a book
- A total of 24 people had read a newspaper
- 14 people had read neither a book nor a newspaper

(i) By drawing a Venn diagram, or otherwise, find the number of people who had read both a book and a newspaper.

Answer [2]

(ii) Two of the 10 people who had read a book are selected at random.

Work out the probability that they had both read a book and a newspaper.

Answer [2]

Section B [48 marks]

Answer **four** questions in this section.

Each question in this section carries 12 marks.

- 7 (a) The variables x and y are connected by the equation $y = 3 + x - \frac{x^2}{2}$.

Some corresponding values of x and y are given in the table below.

| | | | | | | | | | |
|-----|----|----|-----|---|-----|---|-----|----|---|
| x | -3 | -2 | -1 | 0 | 1 | 2 | 3 | 4 | 5 |
| y | | -1 | 1.5 | 3 | 3.5 | 3 | 1.5 | -1 | |

- (i) Complete the table. [1]

- (ii) Using a scale of 2 cm to 1 unit, draw a horizontal x -axis for $-3 \leq x \leq 5$.
Using a scale of 1 cm to 1 unit, draw a vertical y -axis for $-5 \leq y \leq 5$.

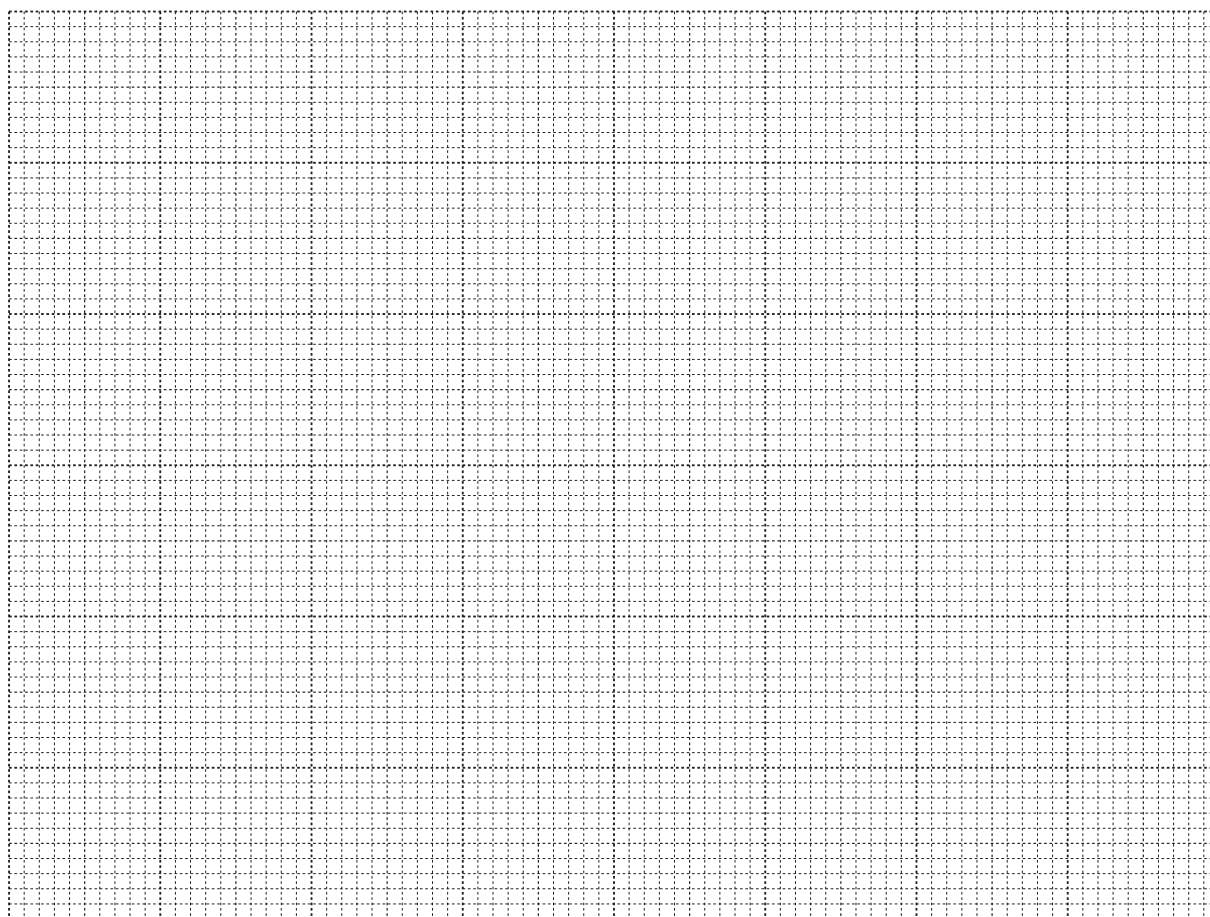
Draw the graph of $y = 3 + x - \frac{x^2}{2}$ for $-3 \leq x \leq 5$.

[3]

- (iii) By drawing a tangent, estimate the gradient of the curve at (3, 1.5).

Answer [2]

- (iv) The points of intersection of the graph of $y = 3 + x - \frac{x^2}{2}$ and the line $y = k$ are the solutions of the equation $10 + 2x - x^2 = 0$.

(a) Find the value of k .

Answer [1]

- (b) By drawing the line $y = k$ on your graph, find the solutions of the equation $10 + 2x - x^2 = 0$.

Answer [2]

- (b) This is a sketch of the graph of $y = pa^x$, where $a > 0$. The graph passes through the points $(0, 4)$ and $(2, 36)$.

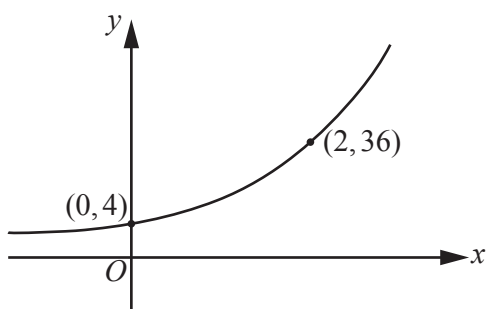

- (i) Write down the value of p .

Answer [1]

- (ii) Find the value of a .

Answer [1]

- (iii) The graph passes through the point $(4, q)$.

Find the value of q .

Answer [1]

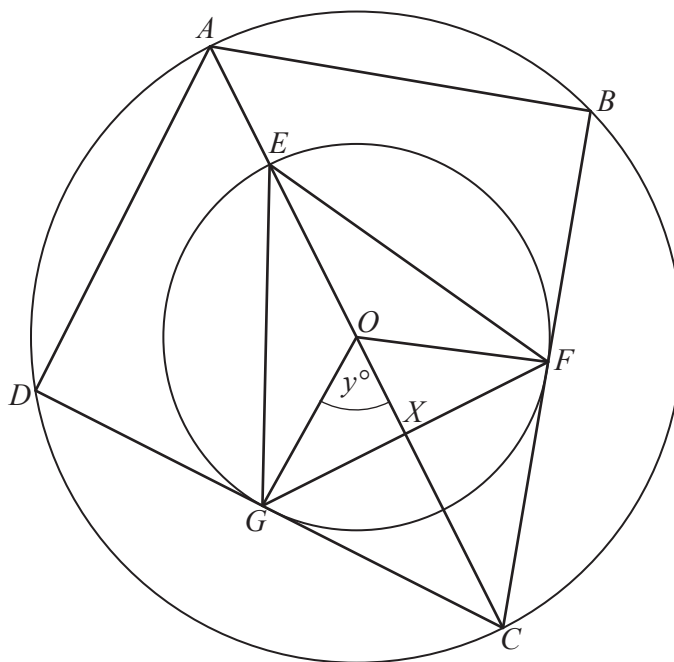

The diagram shows two circles each with centre O .
 A, B, C and D are points on the circumference of the large circle.
 E, F and G are points on the circumference of the small circle.
 CGD and CFB are tangents to the small circle.
 Lines AE and OC intersect at 90° at X .
 $\hat{GOX} = y^\circ$.

(a) Find each of these angles, as simply as possible, in terms of y .
 Give reasons for your answers.

(i) \hat{GEO}

Answer $\hat{GEO} = \dots\dots\dots$ because $\dots\dots\dots$
 $\dots\dots\dots$ [2]

(ii) \hat{GCX}

Answer $\hat{GCX} = \dots\dots\dots$ because $\dots\dots\dots$
 $\dots\dots\dots$ [2]

(iii) \hat{DAB}

Answer $\hat{DAB} = \dots\dots\dots$ because $\dots\dots\dots$
 $\dots\dots\dots$ [2]

(b) Complete the sentence.

Triangle EGC is congruent to triangle [1]

(c) Prove that triangle ADC is similar to triangle OGC .
Give a reason for each statement you make.

.....
.....
.....
..... [2]

(d) What special type of quadrilateral is $AOGD$?

Answer [1]

(e) Find the ratio

(i) area of triangle OGC : area of triangle ADC ,

Answer : [1]

(ii) area of triangle OGC : area of quadrilateral $ABCD$.

Answer : [1]

- 9 (a) The ventilation shaft for a tunnel is in the shape of a cylinder. The cylinder has radius 0.4 m and length 15 m.

Calculate the volume of the cylinder.

Answer m³ [2]

- (b) The diagram shows the cross-section of the tunnel.

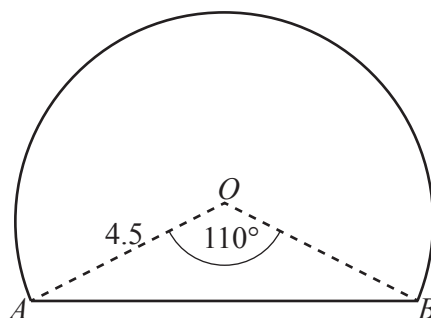

The cross-section of the tunnel is a major segment of a circle, centre O . The radius of the circle is 4.5 m and $\widehat{AOB} = 110^\circ$.

Calculate the area of the cross-section of the tunnel.

Answer m² [4]

- (c) The length of the tunnel is 1750 m.
A car drives through the tunnel at an average speed of 45 km/h.

Work out the time the car takes to travel through the tunnel.
Give your answer in minutes and seconds.

Answer minutes seconds [2]

- (d) The diagram shows the position of the tunnel entrance, T , and two road junctions, P and Q , on horizontal ground.

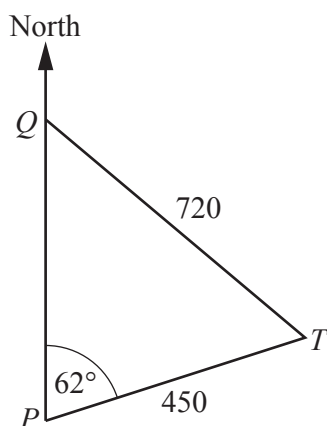

Q is due north of P and T is on a bearing of 062° from P .
 $PT = 450$ m and $QT = 720$ m.

Calculate the bearing of T from Q .

Answer [4]

- 10 A rectangular picture, $ABCD$, is placed inside a rectangular frame.

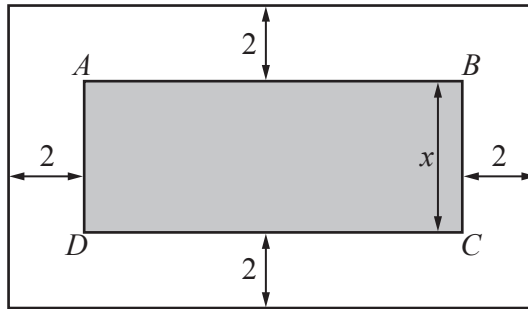

The length, AB , of the picture is three times its height, x cm.
 The width of the frame is 2 cm.

- (a) The total area of the picture and the frame is 476 cm^2 .

Form an equation in x and show that it simplifies to $3x^2 + 16x - 460 = 0$.

[4]

- (b) Solve the equation $3x^2 + 16x - 460 = 0$.

Answer $x = \dots\dots\dots$ or $\dots\dots\dots$ [3]

- (c) Find the height and length of the **frame**.

Answer Height = cm

Length = cm [2]

- (d) The frame is made from wood.
The wood is 5 mm thick.
The mass of 1 cm^3 of the wood is 0.7 g.

Calculate the mass of wood used in the frame.

Answer g [3]

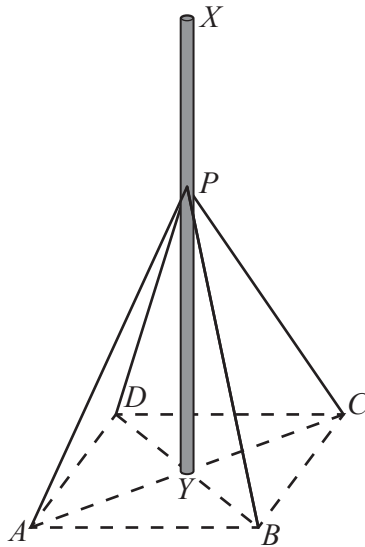

A vertical mast, XY , is positioned on horizontal ground.
 The mast is supported by four cables attached to the mast at P and to the ground at points A , B , C and D .
 Y is the centre of the square $ABCD$.
 $PY = 7.50$ m.

(a) Given that $AB = 3.65$ m, show that $AY = 2.58$ m correct to 3 significant figures.

[3]

(b) Calculate the length of one of the cables used to support the mast.

Answer m [2]

(c) Calculate $\hat{A}PB$.

Answer [3]

(d) The angle of elevation of X from A is 77.0° .

(i) Calculate the height, XY of the mast.

Answer m [2]

(ii) Calculate the angle of elevation of X from the midpoint of AB .

Answer [2]

Permission to reproduce items where third-party owned material protected by copyright is included has been sought and cleared where possible. Every reasonable effort has been made by the publisher (UCLES) to trace copyright holders, but if any items requiring clearance have unwittingly been included, the publisher will be pleased to make amends at the earliest possible opportunity.

To avoid the issue of disclosure of answer-related information to candidates, all copyright acknowledgements are reproduced online in the Cambridge International Examinations Copyright Acknowledgements Booklet. This is produced for each series of examinations and is freely available to download at www.cie.org.uk after the live examination series.

Cambridge International Examinations is part of the Cambridge Assessment Group. Cambridge Assessment is the brand name of University of Cambridge Local Examinations Syndicate (UCLES), which is itself a department of the University of Cambridge.