

UNIVERSITY OF CAMBRIDGE INTERNATIONAL EXAMINATIONS  
General Certificate of Education Ordinary Level

**MATHEMATICS (SYLLABUS D)**

**4024/02**

Paper 2

October/November 2005

**2 hours 30 minutes**

Additional Materials: Answer Booklet/Paper  
Electronic calculator  
Geometrical instruments  
Graph paper (2 sheets)  
Mathematical tables (optional)

**READ THESE INSTRUCTIONS FIRST**

Write your answers and working on the separate Answer Booklet/Paper provided.  
Write your Centre number, candidate number and name on all the work you hand in.  
Write in dark blue or black pen on both sides of the paper.  
You may use a pencil for any diagrams or graphs.  
Do not use staples, paper clips, highlighters, glue or correction fluid.

**Section A**

Answer **all** questions.

**Section B**

Answer any **four** questions.

At the end of the examination, fasten all your work securely together.  
The number of marks is given in brackets [ ] at the end of each question or part question.

Show all your working on the same page as the rest of the answer.  
Omission of essential working will result in loss of marks.  
The total of the marks for this paper is 100.

You are expected to use an electronic calculator to evaluate explicit numerical expressions. You may use mathematical tables as well if necessary.

If the degree of accuracy is not specified in the question, and if the answer is not exact, give the answer to three significant figures. Give answers in degrees to one decimal place.

For  $\pi$ , use either your calculator value or 3.142, unless the question requires the answer in terms of  $\pi$ .

This document consists of **10** printed pages and **2** blank pages.



## Section A [52 marks]

Answer **all** the questions in this section.

1

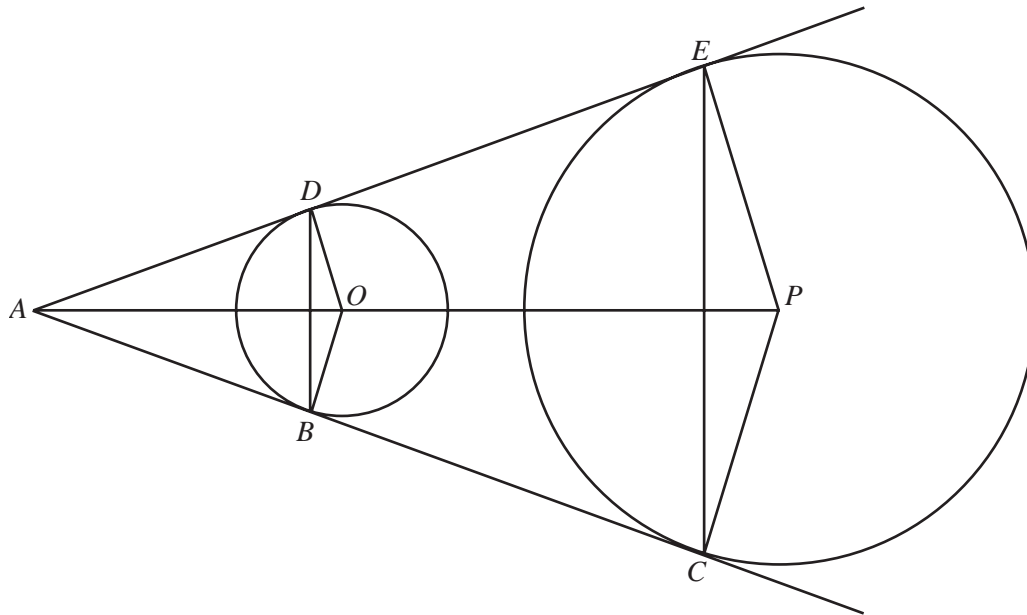

The diagram shows two circles with centres  $O$  and  $P$ .  
 $ABC$  and  $ADE$  are tangents to the circles at  $B$ ,  $C$ ,  $D$  and  $E$  as shown.  
 $AOP$  is a straight line.

- (a) Giving a reason for your answer, write down angle  $ABO$ . [1]
- (b) It is given that  $OB = 6$  cm,  $AO = 13$  cm and  $PC = 15$  cm.
- (i) Show that angle  $OAB = 27.5^\circ$ , correct to one decimal place. [1]
- (ii) Calculate  $AC$ . [2]
- (iii) Calculate  $CE$ . [3]

- 2 (a) Solve the equation  $\frac{3t+1}{2} = 4$ . [2]
- (b) Solve the simultaneous equations
- $$2x + y = 12,$$
- $$3y - 2x = 56. \quad [2]$$
- (c) Simplify  $\frac{3y^2 + 8y + 4}{y^2 - 4}$ . [3]
- (d) Given that  $3h + 2x = 2f - gx$ , express  $x$  in terms of  $f$ ,  $g$  and  $h$ . [3]

3

3

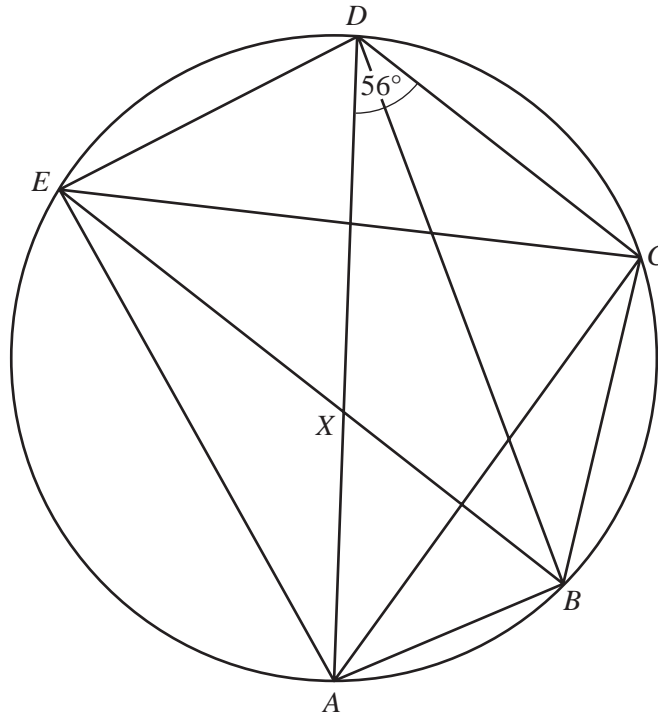

The points  $A$ ,  $B$ ,  $C$ ,  $D$  and  $E$  lie on a circle.  
 $AD$  is a diameter of the circle.  
 $DB$  bisects angle  $ADC$ .  
 Angle  $ADC = 56^\circ$ .

- (a) Giving your reasons, write down
- (i) angle  $DCA$ , [1]
  - (ii) angle  $DAC$ , [1]
  - (iii) angle  $CBA$ , [1]
  - (iv) angle  $AEB$ . [1]
- (b) It is given that  $EB$  is parallel to  $DC$  and that  $EB$  cuts  $AD$  at  $X$ .  
 [You **must not** assume that  $X$  is the centre of the circle.]  
 Show that triangle  $BDX$  is isosceles. [2]
- (c) Find angle  $EBA$ . [1]
- (d) Hence or otherwise show that  $X$  is the centre of the circle. [1]

**4 Answer the whole of this question on a sheet of graph paper.**

The table shows the number of cars owned by each of 25 families.

2	0	3	4	1
0	1	1	2	3
2	3	6	1	0
1	2	0	3	2
3	4	1	2	1

- (a) Draw a bar chart to represent the information in the table. [2]
- (b) Find
- (i) the median number of cars, [1]
  - (ii) the modal number of cars, [1]
  - (iii) the mean number of cars. [1]
- (c) A **family** is chosen at random.  
Find the probability that it owns 3 cars. [1]
- (d) Two **families** are chosen at random.  
Find the probability that one family owns 2 cars and the other owns 4 cars. [2]
- (e) A **car** is chosen at random.  
Find the probability that it belongs to a family which owns 2 cars. [2]
-

- 5 The cost of parking in a car park is 10 cents for each hour. When he parked his car, John had only a large number of 10 cents coins and 20 cent coins to put into the ticket machine. The table shows how he can pay to park his car.

Parking time (hours)	Ways of paying (amounts in cents)	Number of ways of paying to park
1	10	1
2	10 then 10 20	2
3	10 then 10 then 10 10 then 20 20 then 10	3

- (a) Show that there are
- (i) 5 ways to pay for 4 hours, [1]
- (ii) 8 ways to pay for 5 hours. [1]
- (b) The table below shows the number of ways John can pay when parking for various times.

Time (hours)	1	2	3	4	5	6	7		$n$	$n + 1$	$n + 2$
Number of ways	1	2	3	5	8	$a$	$b$		$x$	$y$	$z$

- (i) Find the values of  $a$  and  $b$ . [3]
- (ii) Write down an equation connecting  $x$ ,  $y$  and  $z$ . [1]

- 6 A road tanker holds 24 tonnes of oil.
- (a) In cold weather it can pump out  $x$  tonnes of oil per minute. Write down an expression, in terms of  $x$ , for the number of minutes it takes to empty the tanker in cold weather. [1]
- (b) In hot weather it can pump out  $(x + 0.5)$  tonnes of oil per minute. Write down an expression, in terms of  $x$ , for the number of minutes it takes to empty the tanker in hot weather. [1]
- (c) It takes 2 minutes longer to empty the tanker in cold weather than in hot weather. Write down an equation in  $x$ , and show that it simplifies to
- $$2x^2 + x - 12 = 0. \quad [3]$$
- (d) Solve the equation  $2x^2 + x - 12 = 0$ , giving the solutions **correct to 3 decimal places**. [4]
- (e) Find the time taken, in minutes and seconds, correct to the nearest second, to empty the tanker in cold weather. [2]

## Section B [48 marks]

Answer **four** questions in this section.

Each question in this section carries 12 marks.

7

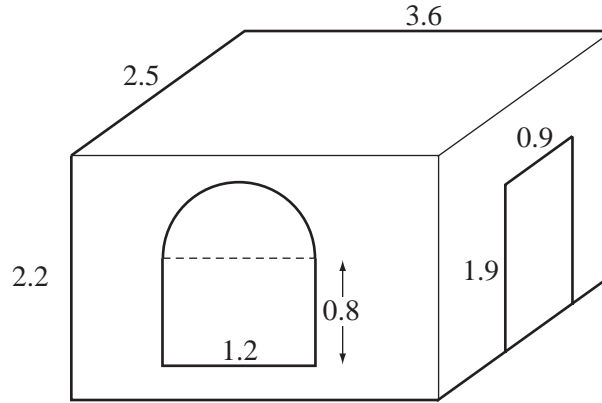

A room has length 3.6 m, width 2.5 m and height 2.2 m.

It has one door which is a rectangle of width 0.9 m and height 1.9 m.

It has one window which is a rectangle of width 1.2 m and height 0.8 m, with a semicircle on one of its longer sides.

- (a) (i) Calculate the area of the window. [2]
- (ii) Show that the area of the walls, correct to three significant figures, is  $23.6 \text{ m}^2$ . [2]
- (b) Tiles are to be fixed to the walls inside the room.  
Eileen estimated the number of tiles needed to cover the walls inside the room in the following way.  
She first increased the area,  $23.6 \text{ m}^2$ , by 12% and then calculated the number of tiles that she needed to cover this total area.  
Each tile is a square of side 25 cm.
- (i) Find the number of tiles that she needed. [3]
- (ii) The tiles are sold in boxes, each containing 20 tiles.  
Each box of tiles costs \$15.  
Calculate the cost of the boxes of tiles that she bought. [2]
- (iii) When the shopkeeper sold the tiles at \$15 per box, he made a profit of 20%.  
Calculate the profit that he made on each box. [3]

8

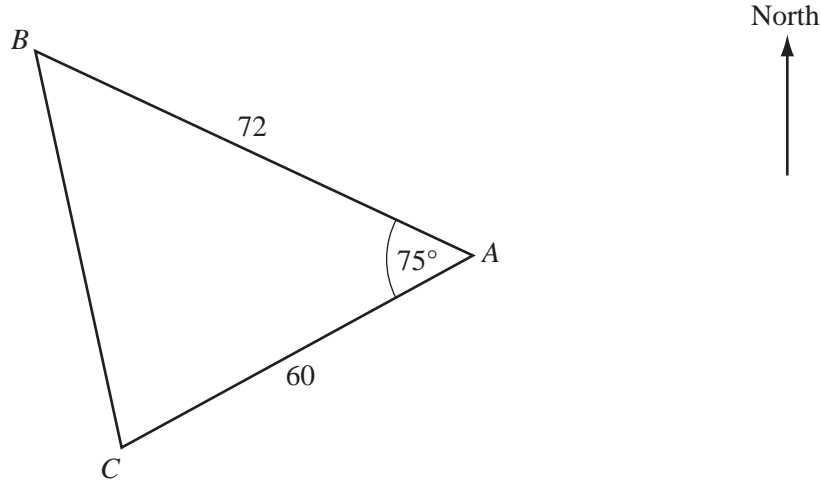

Three points,  $A$ ,  $B$  and  $C$ , lie on a horizontal field.  
 Angle  $BAC = 75^\circ$  and the bearing of  $C$  from  $A$  is  $217^\circ$ .  
 $AB = 72$  m and  $AC = 60$  m.

- (a) Calculate
- (i) the bearing of  $B$  from  $A$ , [1]
  - (ii)  $BC$ , [4]
  - (iii) angle  $ABC$ , [3]
  - (iv) the bearing of  $C$  from  $B$ . [1]
- (b) A girl standing at  $B$  is flying a kite.  
 The kite,  $K$ , is vertically above  $A$ .  
 The string,  $BK$ , attached to the kite is at  $24^\circ$  to the horizontal.  
 Calculate the angle of elevation of the kite when viewed from  $C$ . [3]

9 [The surface area of a sphere =  $4\pi r^2$ .]

[The volume of a sphere =  $\frac{4}{3}\pi r^3$ .]

[The area of the curved surface of a cone of radius  $r$  and slant height  $l$  is  $\pi r l$ .]

[The volume of a cone =  $\frac{1}{3} \times \text{base area} \times \text{height}$ .]

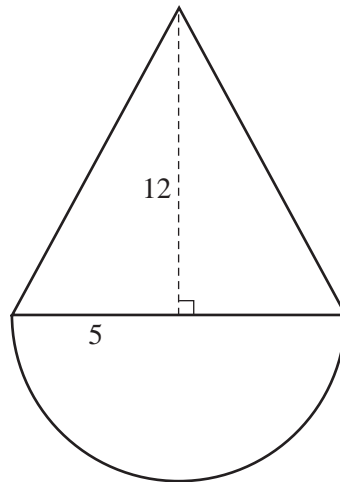

A solid cone has a base radius of 5 cm and height 12 cm.

A solid hemisphere has a radius of 5 cm.

A metal toy is formed by joining the plane faces of the cone and the hemisphere.

- (a) Show that the length of the slant edge of the cone is 13 cm. [1]
- (b) Calculate
- (i) the surface area of the toy, [4]
- (ii) the volume of the toy. [3]
- (c) A solid metal cylinder has a radius of 1.5 m and height 2 m.  
The cylinder was melted down and all of the metal was used to make a large number of these toys.  
Calculate the number of toys that were made. [4]



**10 Answer the whole of this question on a sheet of graph paper.**

The area of a rectangular garden,  $ABCD$ , is  $100 \text{ m}^2$ .  
 Inside the garden there is a rectangular lawn,  $EFGH$ ,  
 whose sides are parallel to those of the garden.  
 $EF$  is 4 m from  $AB$ .  
 $FG$ ,  $GH$  and  $HE$  are 1 m from  $BC$ ,  $CD$  and  $DA$  respectively.

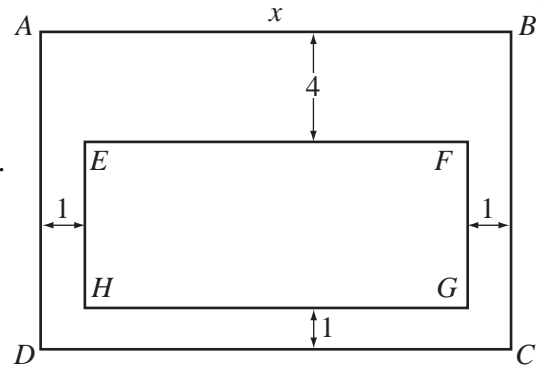

(a) Taking the length of  $AB$  to be  $x$  metres, write down expressions, in terms of  $x$ , for

- (i)  $EF$ ,
- (ii)  $BC$ ,
- (iii)  $FG$ .

[2]

(b) Hence show that the area,  $y$  square metres, of the lawn,  $EFGH$  is given by

$$y = 110 - 5x - \frac{200}{x}. \quad [1]$$

(c) The table below shows some values of  $x$  and the corresponding values of  $y$ , correct to 1 decimal place, where

$$y = 110 - 5x - \frac{200}{x}.$$

$x$	4	5	6	7	8	9	10
$y$	$p$	45.0	46.7	46.4	45.0	42.8	40.0

Find the value of  $p$ .

[1]

(d) Using a scale of 2 cm to 1 metre, draw a horizontal  $x$ -axis for  $4 \leq x \leq 10$ .

Using a scale of 2 cm to 2 square metres, draw a vertical  $y$ -axis for  $40 \leq y \leq 48$ .

On your axes, plot the points given in the table and join them with a smooth curve.

[3]

(e) By drawing a tangent, find the gradient of the curve where  $x = 8$ .

[2]

(f) Use your graph to find

(i) the range of values of  $x$  for which the area of the lawn is at least  $44 \text{ m}^2$ ,

[2]

(ii) the value of  $x$  for which the area of the lawn is greatest.

[1]

11

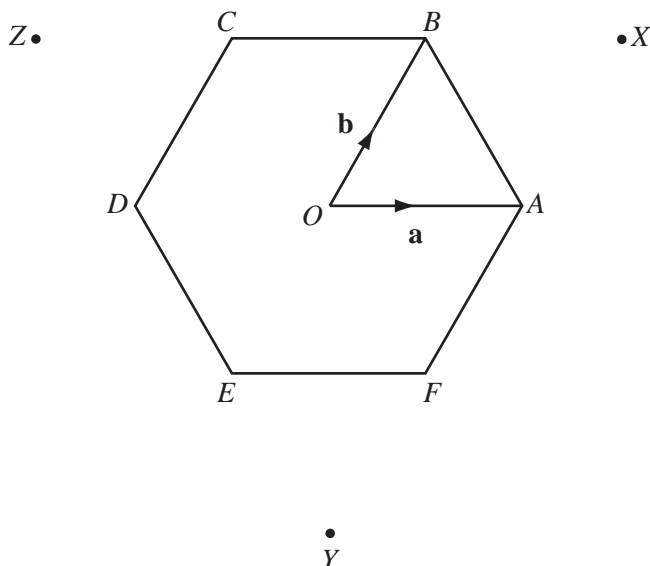

A regular hexagon,  $ABCDEF$ , has centre  $O$ .

$\vec{OA} = \mathbf{a}$  and  $\vec{OB} = \mathbf{b}$ .

(a) Express, as simply as possible, in terms of  $\mathbf{a}$  and/or  $\mathbf{b}$ ,

(i)  $\vec{DO}$ , [1]

(ii)  $\vec{AB}$ , [1]

(iii)  $\vec{DB}$ . [1]

(b) Explain why  $|\mathbf{a}| = |\mathbf{b}| = |\mathbf{b} - \mathbf{a}|$ . [1]

(c) The points  $X$ ,  $Y$  and  $Z$  are such that

$\vec{OX} = \mathbf{a} + \mathbf{b}$ ,  $\vec{OY} = \mathbf{a} - 2\mathbf{b}$  and  $\vec{OZ} = \mathbf{b} - 2\mathbf{a}$ .

(i) Express, as simply as possible, in terms of  $\mathbf{a}$  and/or  $\mathbf{b}$ ,

(a)  $\vec{AX}$ , [1]

(b)  $\vec{YX}$ . [1]

(ii) What can be deduced about  $Y$ ,  $A$  and  $X$ ? [1]

(d) Express, as simply as possible, in terms of  $\mathbf{a}$  and/or  $\mathbf{b}$ , the vector  $\vec{XZ}$ . [1]

(e) Show that triangle  $XYZ$  is equilateral. [2]

(f) Calculate  $\frac{\text{Area of triangle } OAB}{\text{Area of triangle } XYZ}$ . [2]



---

Permission to reproduce items where third-party owned material protected by copyright is included has been sought and cleared where possible. Every reasonable effort has been made by the publisher (UCLES) to trace copyright holders, but if any items requiring clearance have unwittingly been included, the publisher will be pleased to make amends at the earliest possible opportunity.

University of Cambridge International Examinations is part of the University of Cambridge Local Examinations Syndicate (UCLES), which is itself a department of the University of Cambridge.