



Cambridge O Level

CANDIDATE
NAME

CENTRE
NUMBER

--	--	--	--	--

CANDIDATE
NUMBER

--	--	--	--

MATHEMATICS (SYLLABUS D)

4024/12

Paper 1

May/June 2021

2 hours

You must answer on the question paper.

You will need: Geometrical instruments

INSTRUCTIONS

- Answer **all** questions.
- Use a black or dark blue pen. You may use an HB pencil for any diagrams or graphs.
- Write your name, centre number and candidate number in the boxes at the top of the page.
- Write your answer to each question in the space provided.
- Do **not** use an erasable pen or correction fluid.
- Do **not** write on any bar codes.
- Calculators must **not** be used in this paper.
- You may use tracing paper.
- You must show all necessary working clearly.

INFORMATION

- The total mark for this paper is 80.
- The number of marks for each question or part question is shown in brackets [].

This document has **20** pages. Any blank pages are indicated.



ELECTRONIC CALCULATORS MUST NOT BE USED IN THIS PAPER

- 1 (a) Write 0.45 as a fraction in its lowest terms.

..... [1]

- (b) Write these fractions in order of size, starting with the smallest.

$$\frac{4}{5} \quad \frac{7}{10} \quad \frac{17}{20}$$

.....,, [1]
smallest

- 2 Complete the description of the symmetry for each shape.



..... lines of symmetry

Rotational symmetry of order

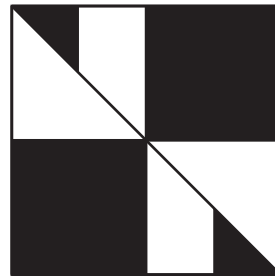

..... lines of symmetry

Rotational symmetry of order

[2]

- 3 A group of 60 students were each asked their favourite fruit. The results are shown in the table.

Fruit	Frequency
Apple	20
Banana	25
Orange	15

Complete the pie chart to show the results.

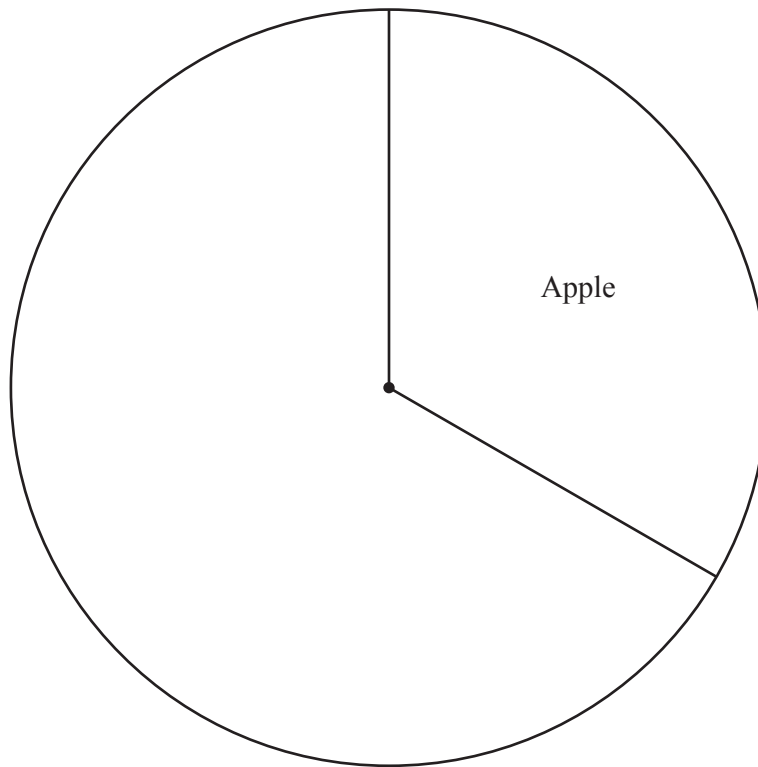

[2]

4 (a) Write 64 785 491 correct to the nearest million.

..... [1]

(b) By writing each number correct to 1 significant figure, estimate the value of

$$\frac{67.8 + 49.5}{0.187^2}$$

..... [2]

5 (a) Omar and Jamil share \$540 in the ratio 7 : 2.

Work out Omar's share.

\$ [2]

(b) Increase 40 in the ratio 5 : 8.

..... [1]

- 6 The base of a cuboid is a square with side length 4 cm.
The volume of the cuboid is 48 cm^3 .

On the grid, complete the accurate drawing of the net of the cuboid.
The base is drawn for you.

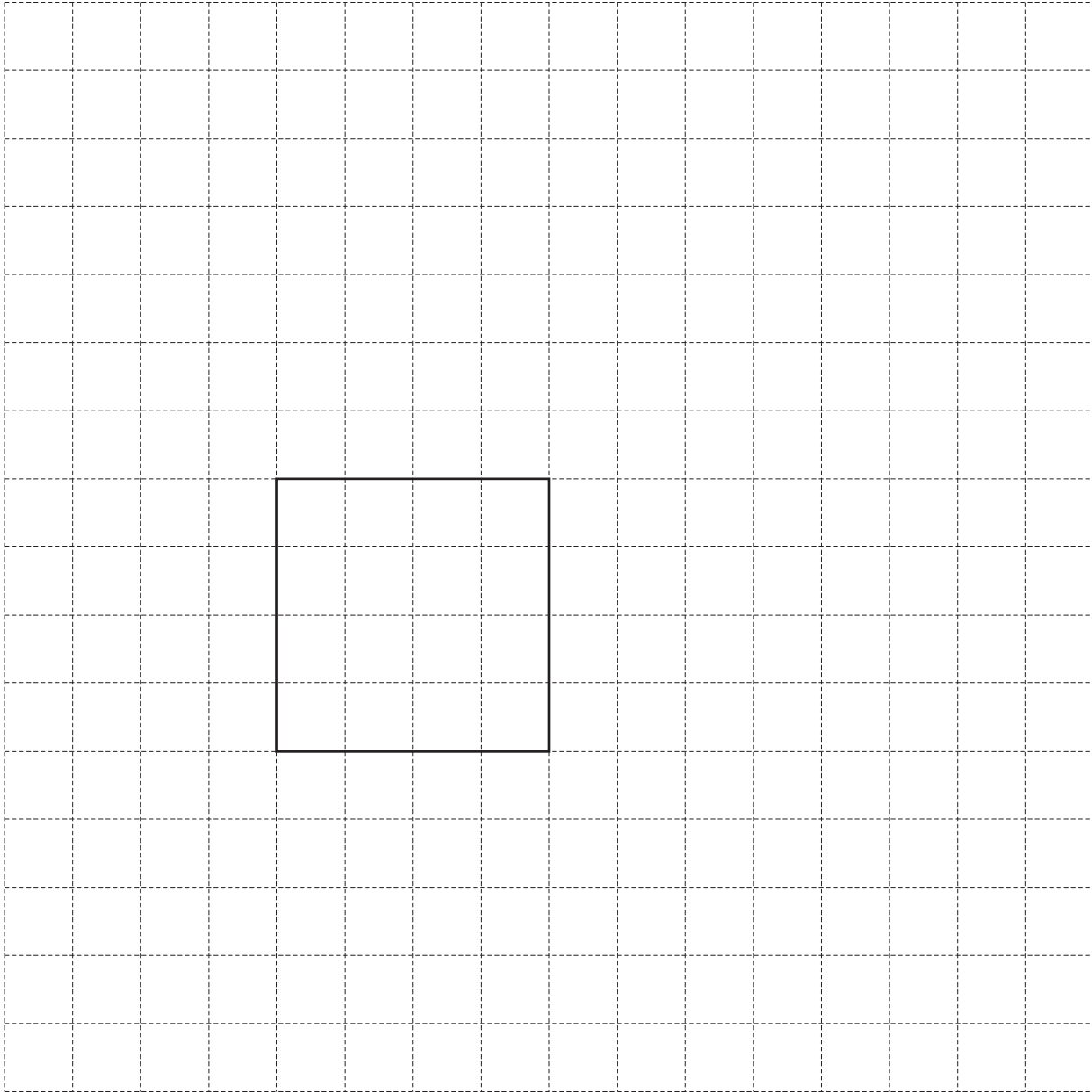

[3]

- 7 A bag contains coloured counters.
A counter is taken from the bag at random.
The table shows the probabilities of taking a counter of each colour.

Colour	Red	Green	Blue	Yellow
Probability	0.15	0.3		0.42

Complete the table.

[2]

- 8 Work out $3\frac{2}{5} - 1\frac{3}{4}$.

Give your answer as a fraction.

..... [2]

9

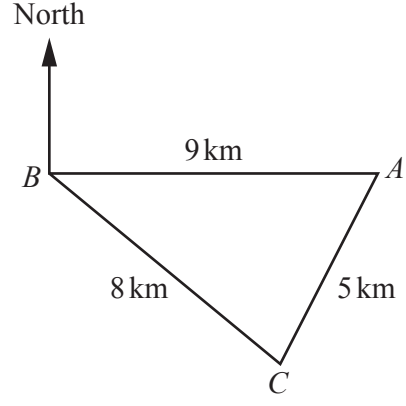

NOT TO SCALE

The sketch shows the positions of three villages, *A*, *B* and *C*.
A is due east of *B*.

- (a) Use a ruler and compasses only to complete the scale drawing of triangle *ABC*.
Use a scale of 1 cm to represent 1 km.



Scale: 1 cm to 1 km

[2]

- (b) Measure the bearing of *C* from *B*.

..... [1]

10 (a) Write 270 as the product of its prime factors.

..... [2]

(b) Find the highest common factor (HCF) of 270 and 225.

..... [2]

11 Solve the simultaneous equations.
Show your working.

$$5x + 2y = 7$$

$$2x - 3y = 18$$

$x =$

$y =$ [4]

- 12 (a) Lara goes for a cycle ride.
The distance–time graph shows her journey.

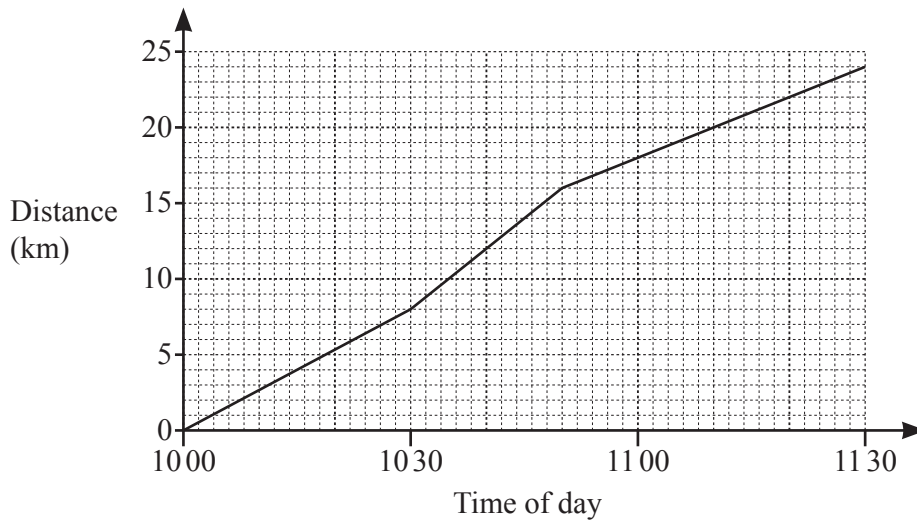

Calculate Lara's average speed, in kilometres per hour, for the whole journey.

..... km/h [3]

- (b) A car travels at a constant speed of 10 m/s for 80 seconds.
It then decelerates at a constant rate of 0.5 m/s^2 until it stops.

On the grid, draw the speed–time graph for this journey.

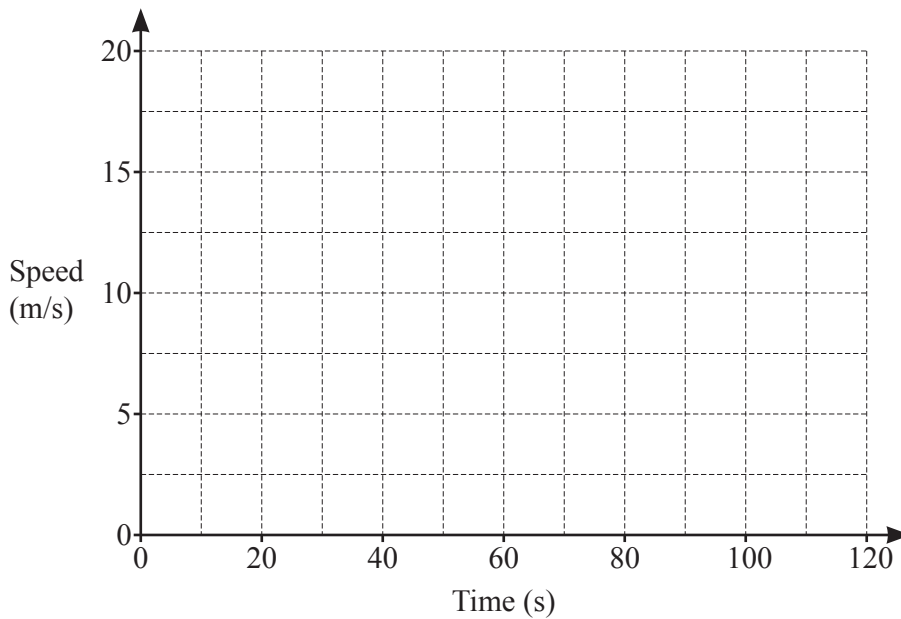

[2]
[Turn over

13 (a) Write 0.000 053 in standard form.

..... [1]

(b) Evaluate $(1.5 \times 10^{14}) \times (8 \times 10^6)$.
Give your answer in standard form.

..... [2]

14 (a) The length of a path is measured as 62 m, correct to the nearest metre.

Write down the upper bound for the length of the path.

..... m [1]

(b) The mass of a bag of peanuts is 80 g, correct to the nearest 10 grams.

Calculate the lower bound for the mass of 5 of these bags of peanuts.

..... g [2]

15 Use a ruler and compasses only in this question.

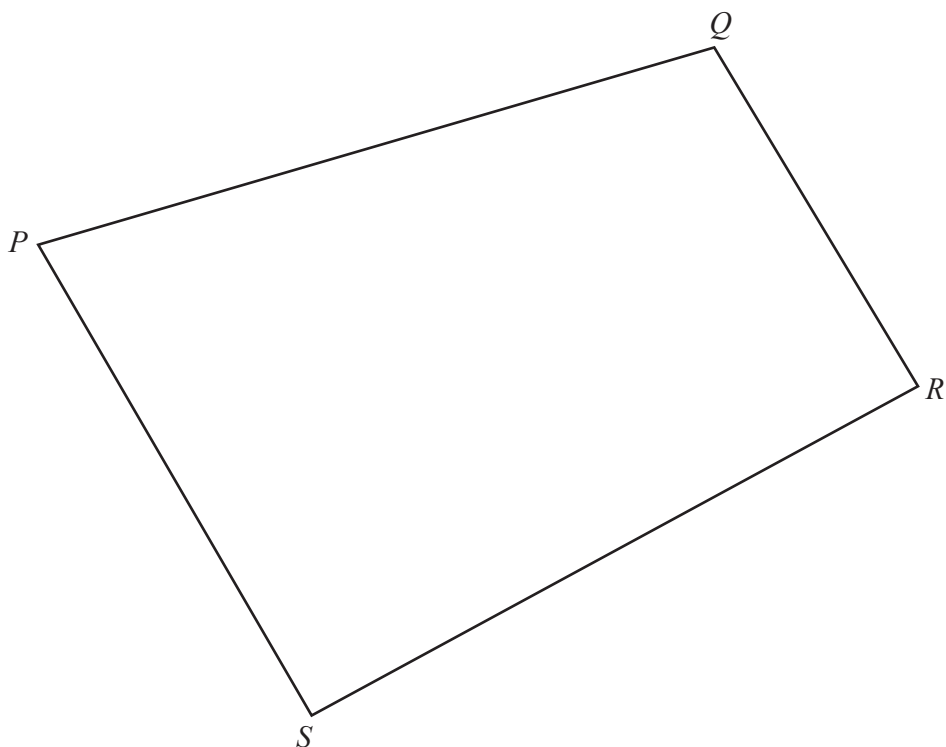

(a) Construct the locus of points inside quadrilateral $PQRS$ that are

(i) 6 cm from S , [1]

(ii) equidistant from QP and QR . [2]

(b) Shade the region inside quadrilateral $PQRS$ containing points that are

- more than 6 cm from S
- and
- closer to QR than to QP . [1]

16 (a) $(y^k)^{-2} = y^5$

Find the value of k .

$k = \dots\dots\dots$ [1]

(b) Simplify $\left(\frac{x^{\frac{1}{3}}}{2x}\right)^3$.

$\dots\dots\dots$ [2]

17 In a sale, the price of a coat is reduced by 25%.
The sale price is \$120.

Calculate the price of the coat before the sale.

\$ $\dots\dots\dots$ [2]

18 y is inversely proportional to the cube of x .

When $x = \frac{1}{2}$, $y = 24$.

(a) Find the formula for y in terms of x .

$y = \dots\dots\dots$ [2]

(b) Find the value of y when $x = \frac{1}{3}$.

$y = \dots\dots\dots$ [1]

- 19 On Monday, 40 adults and 20 children visit a museum.
 On Tuesday, 30 adults and 35 children visit the museum.
 The cost of an adult ticket is \$2.50 and the cost of a child ticket is \$2.

This information can be represented by the matrices \mathbf{M} and \mathbf{N} .

$$\mathbf{M} = \begin{pmatrix} 40 & 20 \\ 30 & 35 \end{pmatrix} \quad \mathbf{N} = \begin{pmatrix} 2.50 \\ 2 \end{pmatrix}$$

- (a) (i) Work out \mathbf{MN} .

$$\mathbf{MN} = \quad [2]$$

- (ii) Explain what the numbers in your answer to **part (a)(i)** represent.

.....
 [1]

- (b) The museum increases the cost of tickets by 10%.

Complete matrix \mathbf{P} to show the new ticket costs.

$$\mathbf{P} = \begin{pmatrix} & \\ & \end{pmatrix} [2]$$

20 Here are the first four terms of a sequence.

$$\frac{12}{16} \quad \frac{17}{25} \quad \frac{22}{36} \quad \frac{27}{49}$$

Find an expression for the n th term of the sequence.

..... [4]

21 (a) Write $x^2 + 10x + 6$ in the form $(x+a)^2 + b$.

..... [2]

(b) Use your answer to **part (a)** to solve $x^2 + 10x + 6 = 0$.
Give your answer in the form $p \pm \sqrt{q}$.

$x =$ [1]

22 Express as a single fraction in its simplest form.

$$\frac{3}{x-7} + \frac{2}{x+5}$$

..... [3]

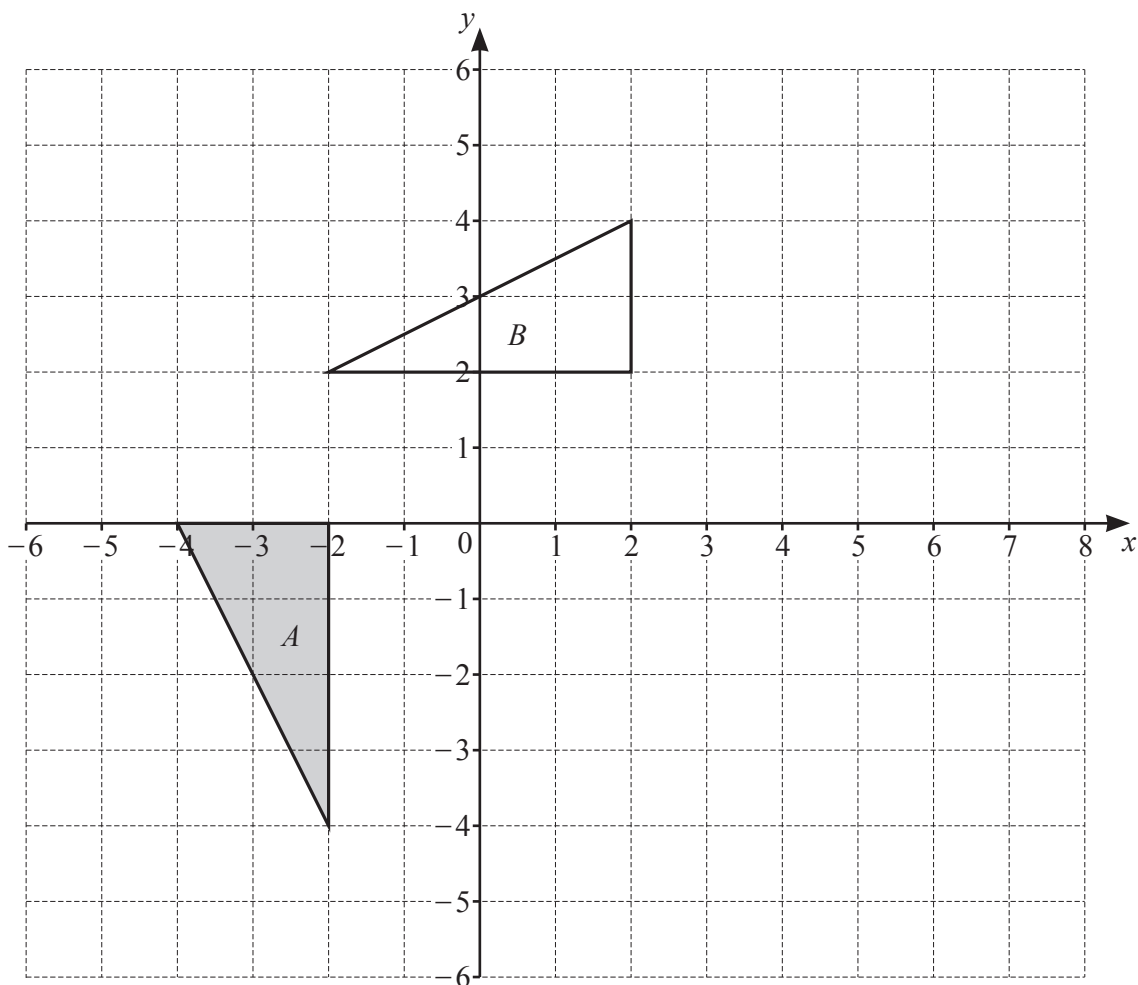

Triangle *A* and triangle *B* are drawn on the grid.

- (a) Describe fully the **single** transformation that maps triangle *A* onto triangle *B*.

.....

[3]

- (b) Transformation *P* is represented by the matrix $\begin{pmatrix} -\frac{1}{2} & 0 \\ 0 & -\frac{1}{2} \end{pmatrix}$.

P maps triangle *A* onto triangle *C*.

On the grid, draw triangle *C*.

[2]

- 24 A group of office workers are each asked to record the distance, d kilometres, they travel to work. The results for some of their journeys are shown in the histogram.

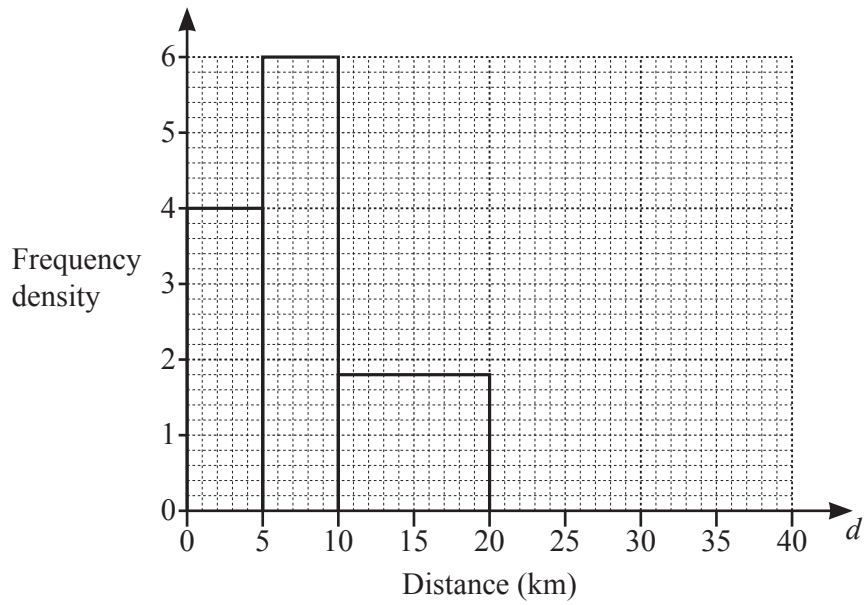

There were 20 workers in the $0 < d \leq 5$ group.

- (a) There were 12 workers in the $20 < d \leq 40$ group.

Complete the histogram.

[1]

- (b) Calculate the percentage of workers who travelled more than 20 km to work.

..... % [3]

25 The algebraic fraction $\frac{2x^2 - 5x + a}{x^2 - 16}$ can be simplified to give $\frac{2x + b}{x + 4}$.

Find the value of a and the value of b .

$$a = \dots\dots\dots$$

$$b = \dots\dots\dots [3]$$

Permission to reproduce items where third-party owned material protected by copyright is included has been sought and cleared where possible. Every reasonable effort has been made by the publisher (UCLES) to trace copyright holders, but if any items requiring clearance have unwittingly been included, the publisher will be pleased to make amends at the earliest possible opportunity.

To avoid the issue of disclosure of answer-related information to candidates, all copyright acknowledgements are reproduced online in the Cambridge Assessment International Education Copyright Acknowledgements Booklet. This is produced for each series of examinations and is freely available to download at www.cambridgeinternational.org after the live examination series.

Cambridge Assessment International Education is part of the Cambridge Assessment Group. Cambridge Assessment is the brand name of the University of Cambridge Local Examinations Syndicate (UCLES), which itself is a department of the University of Cambridge.