

Please write clearly in block capitals.

Centre number

Candidate number

Surname \_\_\_\_\_

Forename(s) \_\_\_\_\_

Candidate signature \_\_\_\_\_

# Level 2 Certificate FURTHER MATHEMATICS

## Paper 2 Calculator

Monday 19 June 2017

Morning

Time allowed: 2 hours

### Materials

For this paper you must have:

- a calculator
- mathematical instruments.

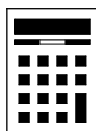

### Instructions

- Use black ink or black ball-point pen. Draw diagrams in pencil.
- Fill in the boxes at the top of this page.
- Answer **all** questions.
- You must answer the questions in the spaces provided. Do not write outside the box around each page or on blank pages.
- Do all rough work in this book. Cross through any work you do not want to be marked.
- In all calculations, show clearly how you work out your answer.

### Information

- The marks for questions are shown in brackets.
- The maximum mark for this paper is 105.
- You may ask for more answer paper, graph paper and tracing paper. These must be tagged securely to this answer book.
- The use of a calculator is expected but calculators with a facility for symbolic algebra must **not** be used.

For Examiner's Use	
Pages	Mark
3	
4 – 5	
6 – 7	
8 – 9	
10 – 11	
12 – 13	
14 – 15	
16 – 17	
18 – 19	
20 – 21	
22 – 23	
24 – 25	
26 – 27	
28 – 29	
30	
<b>TOTAL</b>	



### Formulae Sheet

**Volume of sphere**  $= \frac{4}{3} \pi r^3$

**Surface area of sphere**  $= 4\pi r^2$

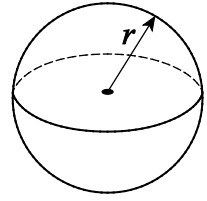

**Volume of cone**  $= \frac{1}{3} \pi r^2 h$

**Curved surface area of cone**  $= \pi r l$

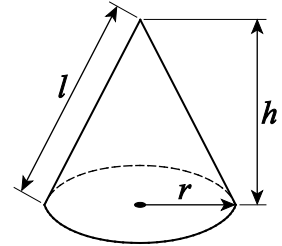

**In any triangle ABC**

**Area of triangle**  $= \frac{1}{2} ab \sin C$

**Sine rule**  $\frac{a}{\sin A} = \frac{b}{\sin B} = \frac{c}{\sin C}$

**Cosine rule**  $a^2 = b^2 + c^2 - 2bc \cos A$

$$\cos A = \frac{b^2 + c^2 - a^2}{2bc}$$

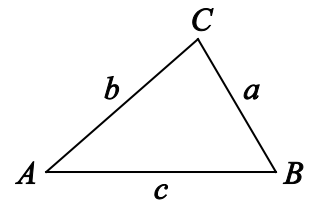

### The Quadratic Equation

The solutions of  $ax^2 + bx + c = 0$ , where  $a \neq 0$ , are given by  $x = \frac{-b \pm \sqrt{(b^2 - 4ac)}}{2a}$

### Trigonometric Identities

$\tan \theta \equiv \frac{\sin \theta}{\cos \theta}$        $\sin^2 \theta + \cos^2 \theta \equiv 1$



Answer **all** questions in the spaces provided.

1 (a) The  $n$ th term of a sequence is  $\frac{3-5n}{2}$

Work out the difference between the 20th term and the 8th term.

[2 marks]

---

---

---

---

---

Answer \_\_\_\_\_

1 (b) The  $n$ th term of another sequence is  $\frac{3n}{1-2n}$

Write down the limiting value of the sequence as  $n \rightarrow \infty$

[1 mark]

Answer \_\_\_\_\_

**Turn over for the next question**



$$2 \quad \mathbf{A} = \begin{pmatrix} 4 & -1 \\ 3 & -2 \end{pmatrix} \quad \mathbf{B} = \begin{pmatrix} 5 \\ 2 \end{pmatrix}$$

2 (a) Work out  $\mathbf{A}^2$

[2 marks]

Answer \_\_\_\_\_

2 (b)  $k\mathbf{B} = \begin{pmatrix} 11-3k \\ 11-6k \end{pmatrix}$  where  $k$  is a constant.

Work out the value of  $k$ .

[2 marks]

Answer \_\_\_\_\_



**2 (c)** Give a reason why it is **not** possible to work out **BA**

[1 mark]

---

---

**Turn over for the next question**

5

**Turn over ►**



3 (a)  $p$ ,  $q$  and  $r$  are all integers greater than 1

$$pqr = 1365$$

Work out one possible set of values for  $p$ ,  $q$  and  $r$ .

[2 marks]

---

---

---

---

---

$$p = \underline{\hspace{2cm}} \quad q = \underline{\hspace{2cm}} \quad r = \underline{\hspace{2cm}}$$

3 (b)  $a$  and  $b$  are both **square** numbers greater than 1

$ab - 11b$  is also a **square** number.

By factorising  $ab - 11b$ , work out one possible pair of values for  $a$  and  $b$ .  
You **must** show your working.

[2 marks]

---

---

---

---

---

$$a = \underline{\hspace{2cm}} \quad b = \underline{\hspace{2cm}}$$



4 Solve  $\frac{56}{\sqrt[3]{x}} = 4$

[2 marks]

---

---

---

---

$x =$  \_\_\_\_\_

Turn over for the next question

6

Turn over ►

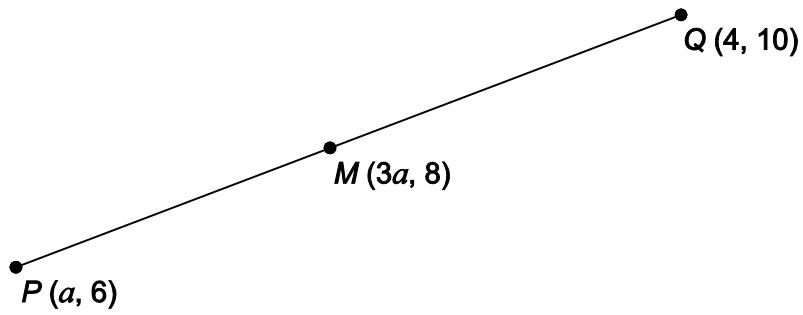

5

 $M$  is the midpoint of  $PQ$ .Not drawn  
accuratelyWork out the value of  $a$ .**[3 marks]**

---

---

---

---

---

---

---

Answer \_\_\_\_\_



- 6 A cone has vertex  $V$ .  
 $C$  is the centre of the base.  
The slant height,  $VA$ , is 20 cm  
The angle between  $VA$  and  $VC$  is  $38^\circ$

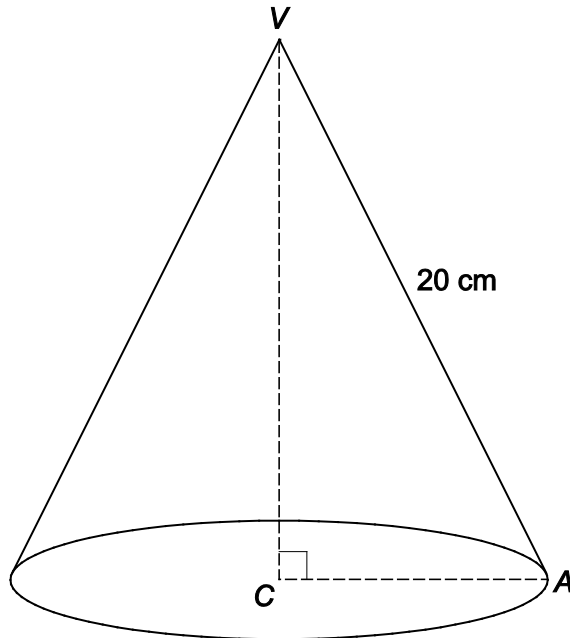

Work out the radius of the base.

[3 marks]

---

---

---

---

---

Answer \_\_\_\_\_ cm

6

Turn over ►



7 The equation of the line through  $B$ ,  $P$  and  $A$  is  $4x + 5y = 40$

$$BP : PA = 2 : 3$$

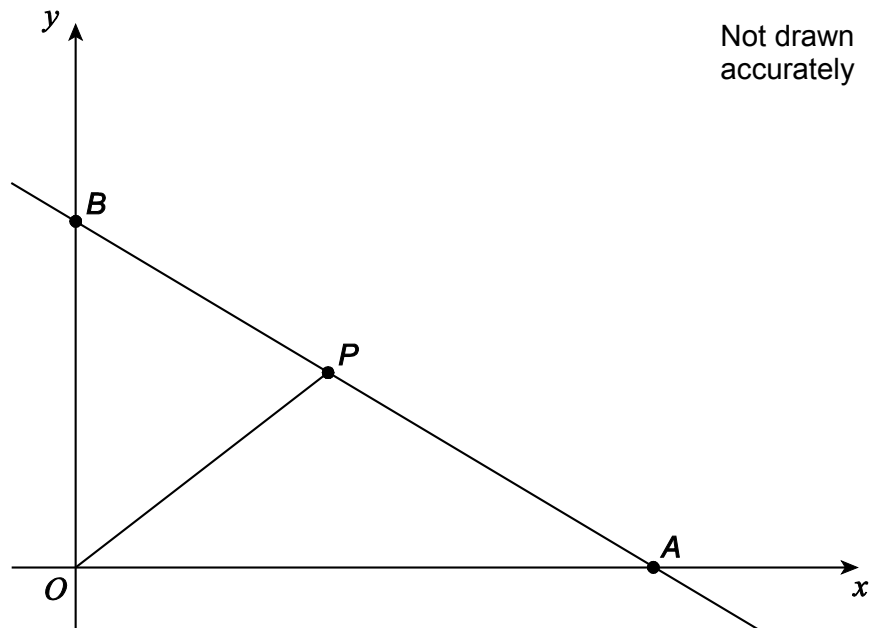

Work out the area of triangle  $OBP$ .

[4 marks]

---



---



---



---



---



---



---



---



---



---

Answer \_\_\_\_\_ square units



- 8 The perimeter of a triangular flower bed,  $ABC$ , is marked out using 27 metres of rope.

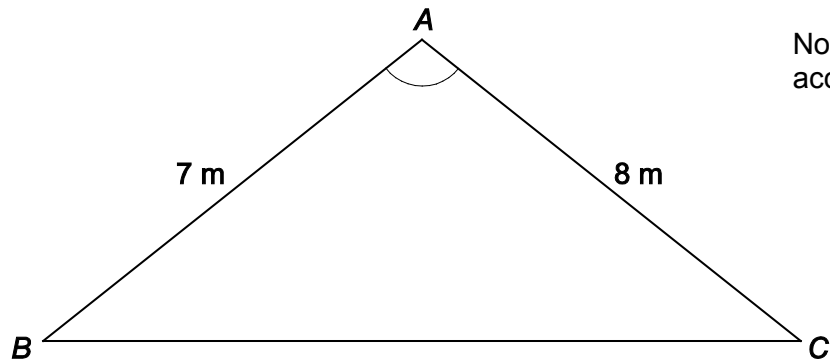

Work out the size of angle  $BAC$ .

[4 marks]

---

---

---

---

---

---

---

---

---

Answer \_\_\_\_\_ degrees

Turn over for the next question





- 10  $ABC$  is an isosceles triangle with  $AB = AC$   
The area of  $ABC$  is  $57.76 \text{ cm}^2$

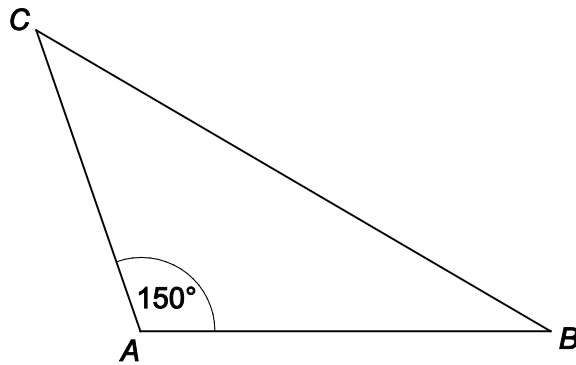

Not drawn  
accurately

Work out the length of  $AB$ .

[3 marks]

---

---

---

---

---

Answer \_\_\_\_\_ cm

Turn over for the next question



11 A function  $f(x)$  is defined as

$$\begin{aligned} f(x) &= 3 - 2x & -2 \leq x < 0 \\ &= (1 + x)(3 - x) & 0 \leq x < 4 \\ &= 5x - 25 & 4 \leq x \leq 5 \end{aligned}$$

11 (a) Draw the graph of  $y = f(x)$  on the axes below.

[4 marks]

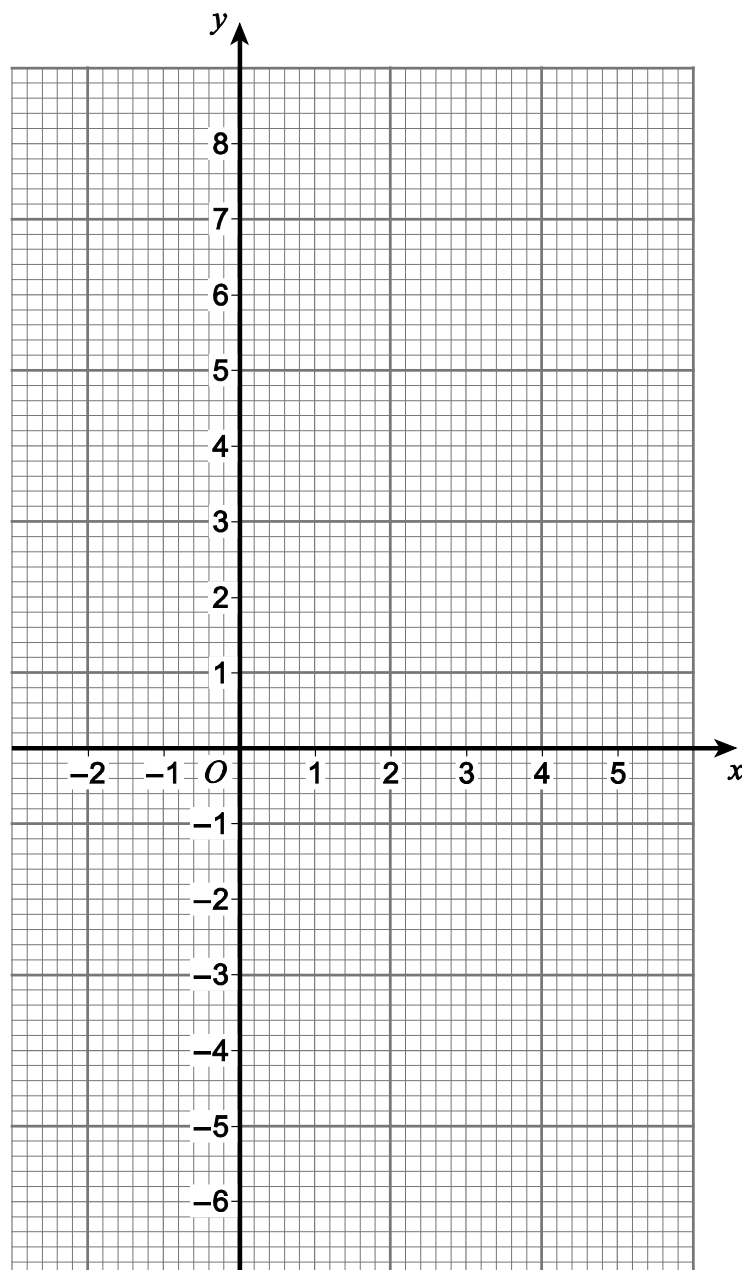

11 (b) State the range of  $f(x)$

[2 marks]

Answer \_\_\_\_\_

12 (a) Factorise fully  $75 - 3x^2$

[2 marks]

---

---

---

Answer \_\_\_\_\_

12 (b) Simplify fully  $(3n + 1)^2 - (3n - 1)^2$

[2 marks]

---

---

---

---

Answer \_\_\_\_\_



13

Simplify fully

$$\frac{8a}{3a+6} \times \frac{5a+10}{3a^2} \div \frac{4}{15a^3}$$

[3 marks]

Answer \_\_\_\_\_





15 Rearrange  $w = \frac{8x - y}{y}$  to make  $y$  the subject.

[3 marks]

Answer \_\_\_\_\_



**16 (a)**  $a = 3^{2b}$

Circle the correct expression for  $\frac{1}{a}$ **[1 mark]**

$3^{2b-1}$

$3^{-2b}$

$-3^{2b}$

$\left(\frac{1}{3}\right)^{-2b}$

**16 (b)**  $y = 5^x$

Circle the correct expression for  $25y$ **[1 mark]**

$5^{x+2}$

$25^x$

$5^{2x}$

$125^x$

**16 (c)**  $w = 2^m$

Circle the correct expression for  $w^3$ **[1 mark]**

$8^{3m}$

$6^m$

$2^{m+3}$

$2^{3m}$

**Turn over for the next question****Turn over ►**

17

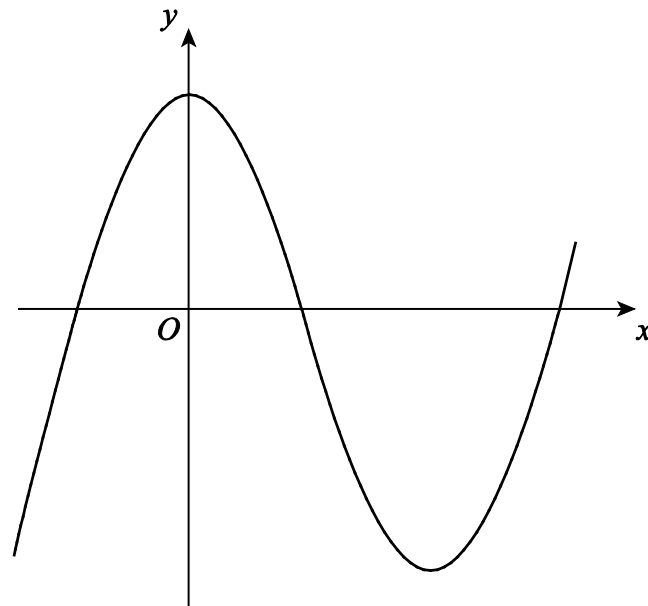
Here is a sketch of  $y = x^3 - 6x^2 + 7$ Not drawn  
accurately

17 (a)

Use differentiation to work out the coordinates of the stationary point that is a minimum. You **must** show your working.**[4 marks]**

---

---

---

---

---

---

---

---

---

---

Answer ( \_\_\_\_\_ , \_\_\_\_\_ )







- 19 Here is a sketch of  $y = \sin x$  for  $0^\circ \leq x \leq 360^\circ$

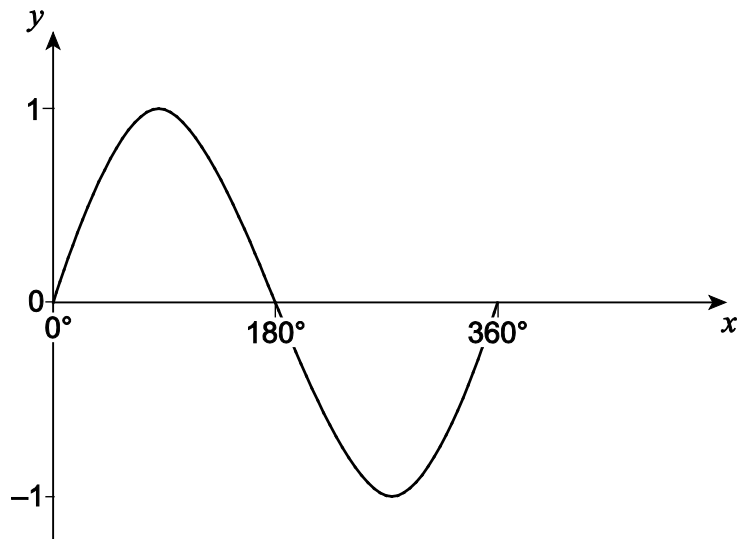

Not drawn accurately

$\alpha$  is an acute angle measured in degrees.

$\sin \alpha = k$  where  $k$  is a constant.

Write the answers to each of the following in terms of  $k$ , without involving trigonometric functions.

19 (a)  $\sin(180^\circ - \alpha)$

[1 mark]

Answer \_\_\_\_\_

19 (b)  $\sin(360^\circ - \alpha)$

[1 mark]

Answer \_\_\_\_\_

19 (c)  $\cos \alpha$

[2 marks]

Answer \_\_\_\_\_

Turn over ►



20

Two circles overlap.

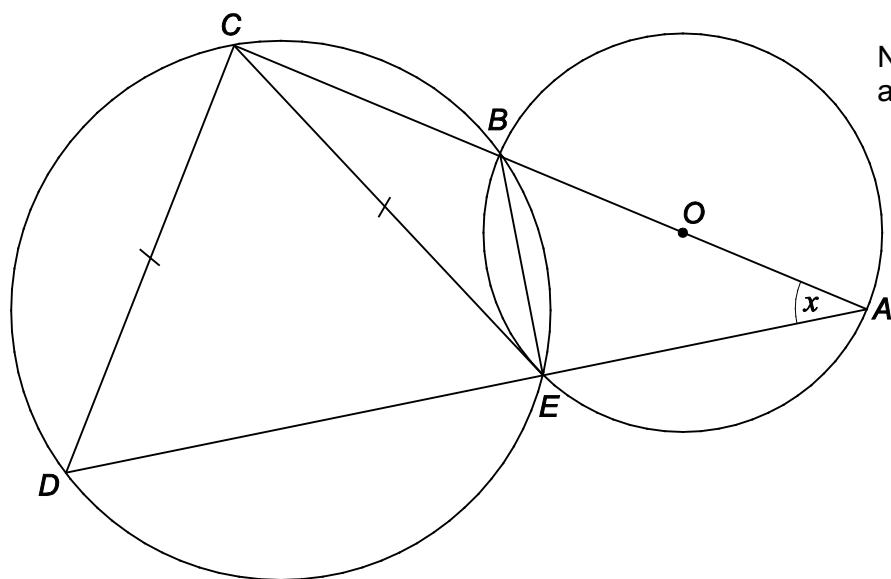
 $A, B$  and  $E$  lie on the circle, centre  $O$ . $B, C, D$  and  $E$  lie on the other circle. $AOBC$  and  $AED$  are straight lines. $CD = CE$ angle  $BAE = x$ 20 (a) Give a reason why angle  $BEA = 90^\circ$ 

[1 mark]

---



---





21 Here is a sketch of  $y = (x + 2)(4 - x)$

The graph intersects the axes at  $A(-2, 0)$ ,  $B(4, 0)$  and  $C$ .

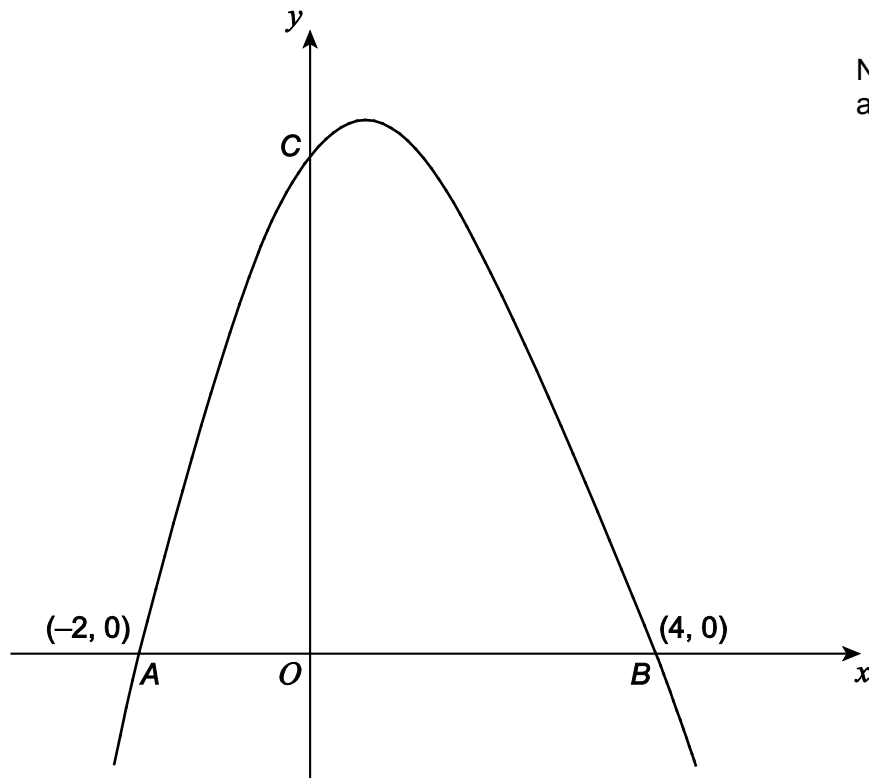

21 (a) Work out the coordinates of  $C$ .

[1 mark]

---

Answer ( \_\_\_\_\_ , \_\_\_\_\_ )







23

In this question,  $\tan x \neq 0$  and  $\sin x \neq 0$

Show that  $\frac{1}{\tan^2 x} - \frac{1}{\sin^2 x}$  is a constant.

**[3 marks]**

Turn over for the next question

—
8

**Turn over ►**



There are no questions printed on this page

**DO NOT WRITE ON THIS PAGE  
ANSWER IN THE SPACES PROVIDED**



**There are no questions printed on this page**

**DO NOT WRITE ON THIS PAGE  
ANSWER IN THE SPACES PROVIDED**

**Copyright Information**

For confidentiality purposes, from the November 2015 examination series, acknowledgements of third party copyright material will be published in a separate booklet rather than including them on the examination paper or support materials. This booklet is published after each examination series and is available for free download from [www.aqa.org.uk](http://www.aqa.org.uk) after the live examination series.

Permission to reproduce all copyright material has been applied for. In some cases, efforts to contact copyright-holders may have been unsuccessful and AQA will be happy to rectify any omissions of acknowledgements. If you have any queries please contact the Copyright Team, AQA, Stag Hill House, Guildford, GU2 7XJ.

Copyright © 2017 AQA and its licensors. All rights reserved.

