

UNIVERSITY OF CAMBRIDGE INTERNATIONAL EXAMINATIONS
General Certificate of Education
Advanced Subsidiary Level and Advanced Level

MATHEMATICS

9709/01

Paper 1 Pure Mathematics 1 (P1)

May/June 2004

1 hour 45 minutes

Additional materials: Answer Booklet/Paper
Graph paper
List of Formulae (MF9)

READ THESE INSTRUCTIONS FIRST

If you have been given an Answer Booklet, follow the instructions on the front cover of the Booklet.
Write your Centre number, candidate number and name on all the work you hand in.
Write in dark blue or black pen on both sides of the paper.
You may use a soft pencil for any diagrams or graphs.
Do not use staples, paper clips, highlighters, glue or correction fluid.

Answer **all** the questions.

Give non-exact numerical answers correct to 3 significant figures, or 1 decimal place in the case of angles in degrees, unless a different level of accuracy is specified in the question.
At the end of the examination, fasten all your work securely together.

The number of marks is given in brackets [] at the end of each question or part question.

The total number of marks for this paper is 75.

Questions carrying smaller numbers of marks are printed earlier in the paper, and questions carrying larger numbers of marks later in the paper.

The use of an electronic calculator is expected, where appropriate.

You are reminded of the need for clear presentation in your answers.

This document consists of **4** printed pages.



- 1 A geometric progression has first term 64 and sum to infinity 256. Find
- (i) the common ratio, [2]
- (ii) the sum of the first ten terms. [2]
- 2 Evaluate $\int_0^1 \sqrt{3x+1} \, dx$. [4]
- 3 (i) Show that the equation $\sin^2 \theta + 3 \sin \theta \cos \theta = 4 \cos^2 \theta$ can be written as a quadratic equation in $\tan \theta$. [2]
- (ii) Hence, or otherwise, solve the equation in part (i) for $0^\circ \leq \theta \leq 180^\circ$. [3]
- 4 Find the coefficient of x^3 in the expansion of
- (i) $(1+2x)^6$, [3]
- (ii) $(1-3x)(1+2x)^6$. [3]
- 5

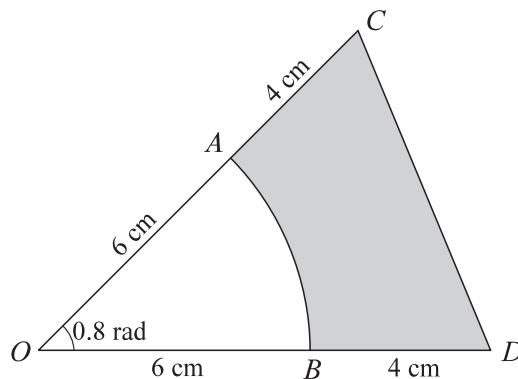

In the diagram, OCD is an isosceles triangle with $OC = OD = 10$ cm and angle $COD = 0.8$ radians. The points A and B , on OC and OD respectively, are joined by an arc of a circle with centre O and radius 6 cm. Find

- (i) the area of the shaded region, [3]
- (ii) the perimeter of the shaded region. [4]

6 The curve $y = 9 - \frac{6}{x}$ and the line $y + x = 8$ intersect at two points. Find

(i) the coordinates of the two points, [4]

(ii) the equation of the perpendicular bisector of the line joining the two points. [4]

7

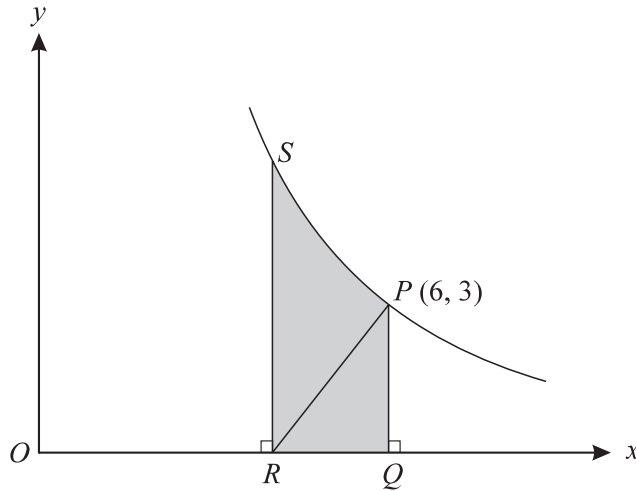

The diagram shows part of the graph of $y = \frac{18}{x}$ and the normal to the curve at $P(6, 3)$. This normal meets the x -axis at R . The point Q on the x -axis and the point S on the curve are such that PQ and SR are parallel to the y -axis.

(i) Find the equation of the normal at P and show that R is the point $(4\frac{1}{2}, 0)$. [5]

(ii) Show that the volume of the solid obtained when the shaded region $PQRS$ is rotated through 360° about the x -axis is 18π . [4]

[Questions 8, 9 and 10 are printed overleaf.]

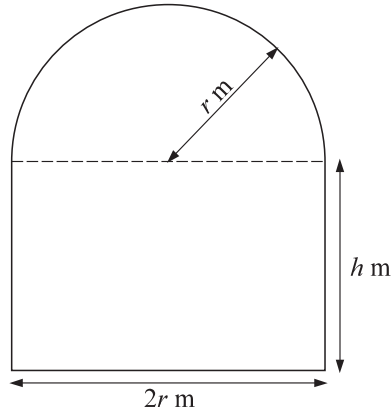

The diagram shows a glass window consisting of a rectangle of height h m and width $2r$ m and a semicircle of radius r m. The perimeter of the window is 8 m.

(i) Express h in terms of r . [2]

(ii) Show that the area of the window, A m², is given by

$$A = 8r - 2r^2 - \frac{1}{2}\pi r^2. \quad [2]$$

Given that r can vary,

(iii) find the value of r for which A has a stationary value, [4]

(iv) determine whether this stationary value is a maximum or a minimum. [2]

9 Relative to an origin O , the position vectors of the points A , B , C and D are given by

$$\overrightarrow{OA} = \begin{pmatrix} 1 \\ 3 \\ -1 \end{pmatrix}, \quad \overrightarrow{OB} = \begin{pmatrix} 3 \\ -1 \\ 3 \end{pmatrix}, \quad \overrightarrow{OC} = \begin{pmatrix} 4 \\ 2 \\ p \end{pmatrix} \quad \text{and} \quad \overrightarrow{OD} = \begin{pmatrix} -1 \\ 0 \\ q \end{pmatrix},$$

where p and q are constants. Find

(i) the unit vector in the direction of \overrightarrow{AB} , [3]

(ii) the value of p for which angle $AOC = 90^\circ$, [3]

(iii) the values of q for which the length of \overrightarrow{AD} is 7 units. [4]

10 The functions f and g are defined as follows:

$$f : x \mapsto x^2 - 2x, \quad x \in \mathbb{R},$$

$$g : x \mapsto 2x + 3, \quad x \in \mathbb{R}.$$

(i) Find the set of values of x for which $f(x) > 15$. [3]

(ii) Find the range of f and state, with a reason, whether f has an inverse. [4]

(iii) Show that the equation $gf(x) = 0$ has no real solutions. [3]

(iv) Sketch, in a single diagram, the graphs of $y = g(x)$ and $y = g^{-1}(x)$, making clear the relationship between the graphs. [2]